



SYNERGY
TECHNICAL MANUAL

CONTENTS

SECTION ONE

COUNTER ARRANGEMENTS

Arrangement of drop ins in counters	3
Counter top cut-outs	3
Rear panel arrangements for heated units	4
Models without gantries	4
Control consoles	4
Refrigerated units	5
Refrigeration venting options	6-9
Refrigeration venting grills	10

SECTION TWO

SPECIFICATIONS

Curved Glass - Heated	11-13
Curved Glass - Refrigerated	14-15
Flat Glass - Heated	16-18
Flat Glass - Refrigerated	19-20
Units without Gantry	20-21
Other Units	21-22

SECTION THREE

DIMENSIONED DRAWINGS

HEATED UNITS

Ceramic Hotplates,

Dry Heat Bains Maire (65mm deep) DHHP, SSHHP, SFHHP, DHBM, SSHBM, SFHBM	23
--	----

Dry Heat Bains Maire (150mm deep) DHBD, SSHBD, SFHBD	24
---	----

Wet/Dry Heat Bains Maire DHBW, SSHBW, SFHBW	25
--	----

Heated Recessed Top / Deli Units DHRT, SSHRT, SFHRT, DHDL, SFHDL	26
---	----

REFRIGERATED UNITS

Refrigerated Well DRWL, DRIW, SSRWL, SFRWL, SSRIW	27
--	----

Refrigerated Decks & Delis DRDK, SSRDK, DRDL, SFRDL	28
--	----

Refrigerated High Delis DHDH	29
---------------------------------	----

Refrigerated Multi-tiers DRMT, SSRMT	30
---	----

COUNTER ARRANGEMENTS

Arrangement of Drop Ins in Counters

Drop in units are not complete products, they are only components of a finished counter. They have some requirements which need to be met in order to achieve satisfactory performance. Please ensure that: you create the right environment for the drop ins and that the installer puts the drop ins into the counter correctly.

Module units utilise a cut out in the counter top with the carcass projecting into cavity or cupboard below. The unit may be installed with the outer flange resting on the counter top (**Method 1**) or the flange can be inset into the counter top (**Method 2**). It is essential that the counter top is perfectly level before the unit is installed and should incorporate some feature such as adjustable levelling feet.

Method 1 is easier and is more suitable if the counter top uses thin surface materials.

Method 2 involves more work but gives a neater installation and is more suitable for thick or solid surface materials.

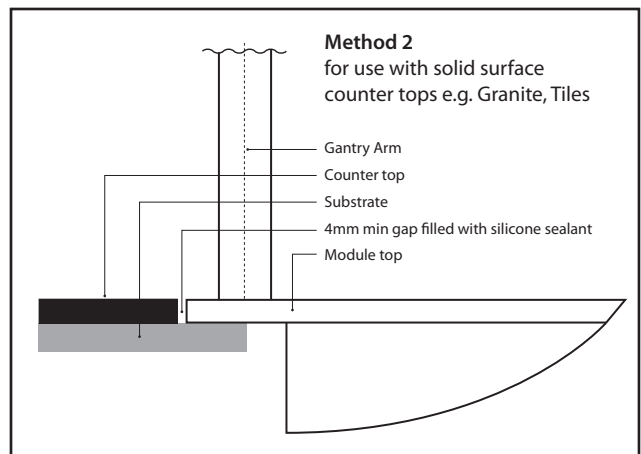
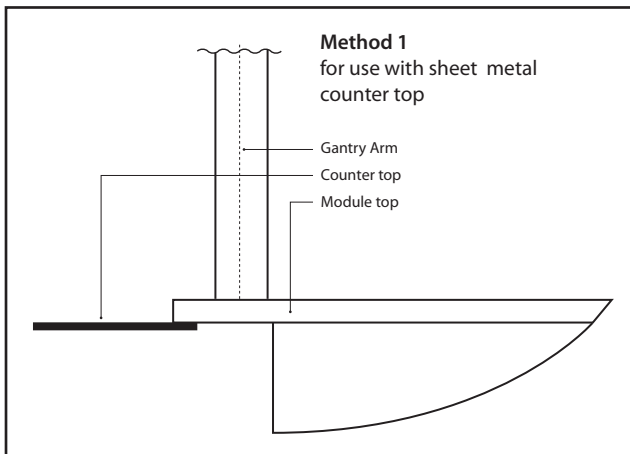

Counter Top Cut-outs

Each unit is dropped into the counter top. The size of the cut out required is detailed within the specification of each unit. For sheet metal or Granite top counters the cut out can have square corners.

Where heated Synergy appliances are used in laminate worktops, the following cut-out arrangements should be adhered to:

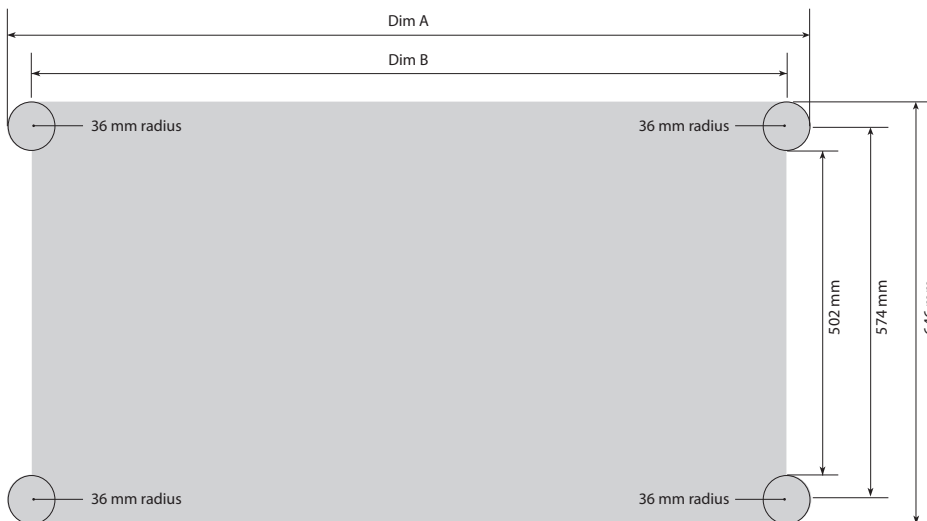

UNIT SIZE	DIM A	DIM B
1 pan	477mm	405mm
2 pan	797mm	725mm
3 pan	1117mm	1045mm
4 pan	1442mm	1370mm
5 pan	1772mm	1700mm
6 pan	2097mm	2025mm

Victor Manufacturing Ltd will not accept responsibility for Laminate cracking faults if these instructions are not followed.

COUNTER ARRANGEMENTS

Rear panel arrangements for Heated units

All heated drop-ins require service access to the rear of the units for access to the elements and other electrical wiring. If the counter is against a wall then access is required from the front. Wet Well bain marie units require additional access to the drain tap as shown.

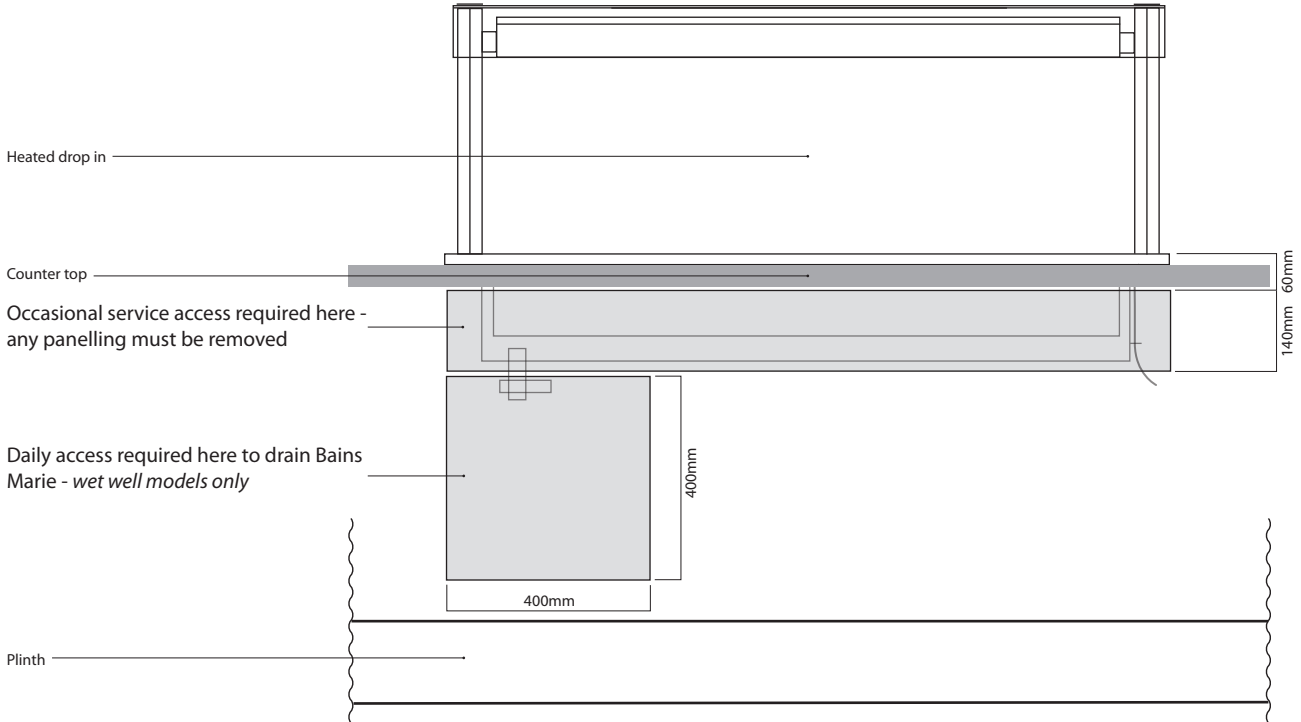

Models without gantries

Heated Units

Heated units without gantries are supplied with 1.5 metres of cable and an energy regulator (supplied loose) for mounting into a suitable control panel. This method is designed for experience counter builders and should be wired in accordance with the latest electrical wiring regulations.

For ease of installation an optional Victor control box can be purchased at addition cost. Dimension details below.

Control consoles

Models without gantries have separate control consoles, which need to be fitted into a 280mm x 116mm cut out in the counter rear vertical panel. The electrical wires from the unit need to be pulled through the control aperture and plugged into the control console before the console is fixed to the panel. Refrigerated units without gantries are supplied with a dimensionally similar control box with a mains cable and a plug inconnector operating the refrigerated unit.

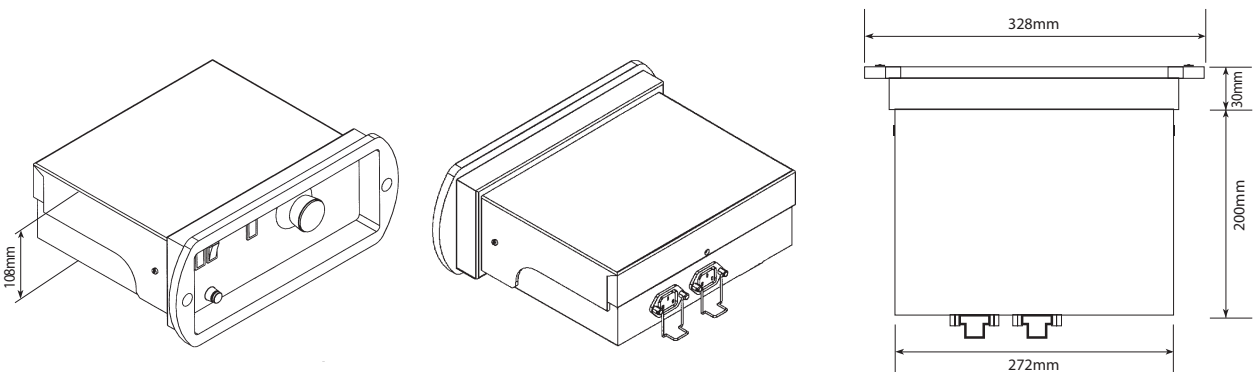

REFRIGERATED UNITS

Refrigerated units

In order to create a successful counter you **must**:

1. Provide adequate ventilation through the drop in and counter.
2. Prevent hot air exhaust re-circulating into the cold air intake
3. Provide access to clean the condenser. Cleaning needs to be carried out at least every 6 months.
4. Provide adequate service access.

Note: failure to provide proper ventilation and access to refrigerated units will invalidate any warranty

BIG AIR INLET & OUTLET VENTS MUST BE PROVIDED



No vent for cool air into refrigeration

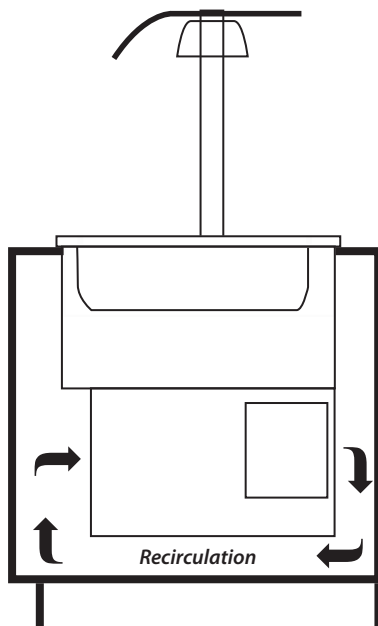

No vent for warm air out off refrigeration

- Refrigeration circuit overheats
 - Component failure likely
 - Well not cold enough
- WARRANTY VOID**



Cool air into refrigeration

To prevent air re-circulation secure slide out baffle using fixing holes provided

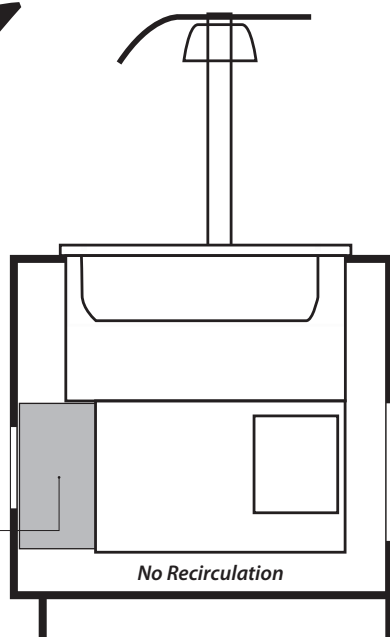

Warm air out of refrigeration

- Refrigeration circuit properly ventilated
- Well down to temperature

REFRIGERATED VENTING - THROUGH VENTILATION

Through Ventilation The best method

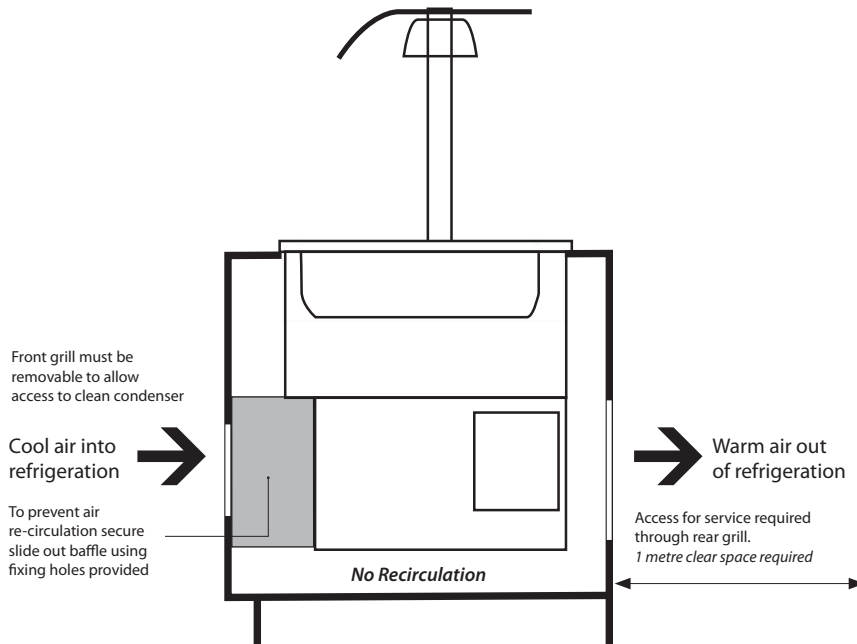

Through venting is the simplest and most efficient method.

- Ensure that the holes to the correct size are cut in both the front and rear of the counter.
- Drop the unit into the hole cut in the counter top ensuring that the condenser is aligned with the hole at the front of the counter.
- Slide out the baffle from the condenser housing and fix into position.
- Fix grills supplied to counter panels. These grills should easily be removed for cleaning and servicing.

See page 10 for detail of grills.

Front Elevation of Counter

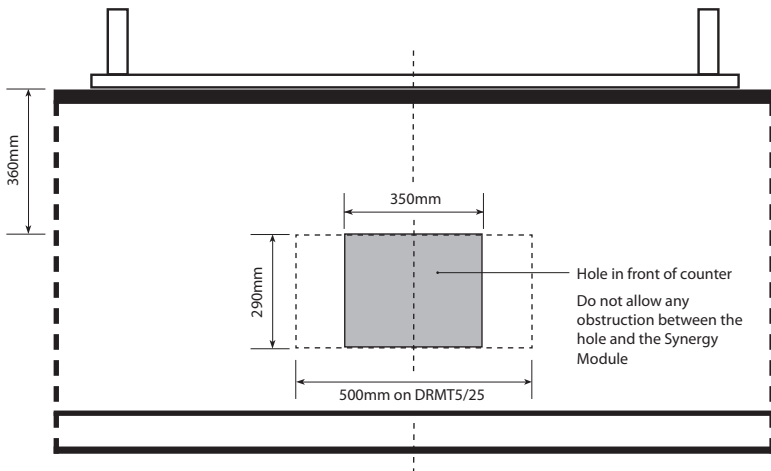

Front of Counter

- Cut a hole through the front of the counter as shown.
- Fit the small grill supplied over the aperture.
- Cleaning access is to be gained via this grill, so it needs to be removable.

Rear Elevation of Counter

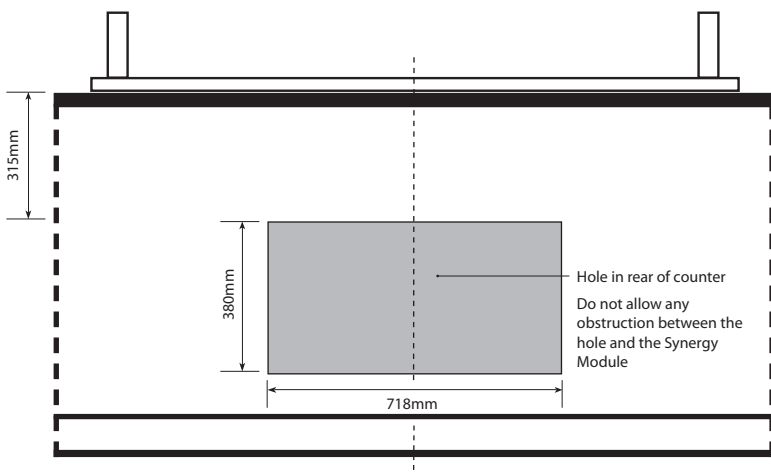

Rear of Counter

- Cut a hole through the rear of the counter as shown.
- Fit the large grill supplied over the aperture.
- Service access is to be gained via this grill, so it needs to be removable.

See page 10 for detail of grills.

REFRIGERATED VENTING - UNITS AGAINST A WALL METHOD 1

Units against a wall - Method 1 Air in the front out up through the rear

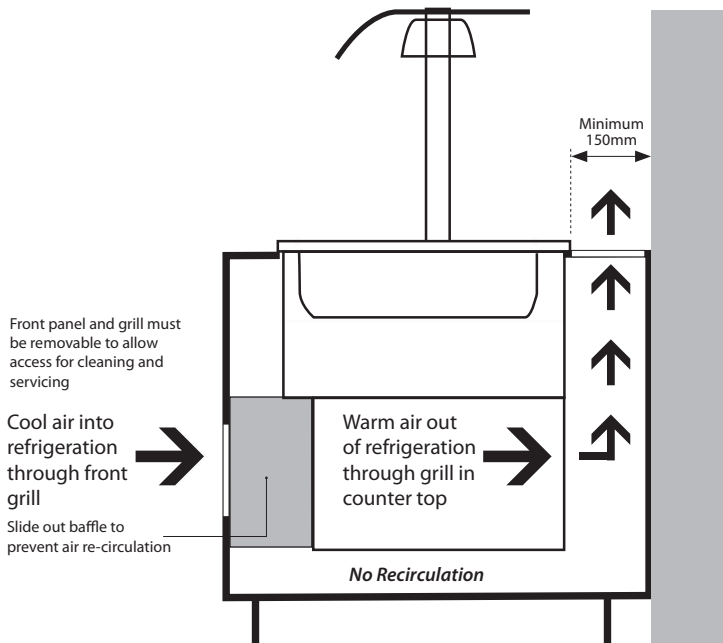

For units sited against a wall

It is preferable to order the Customer facing control version of the required drop in. These have controls to the front and are supplied with a full length rear grill to be fitted on the counter top behind the unit

- Rear of the unit must be a minimum of 150mm away from wall.
- Drop the unit into the hole cut in the counter top ensuring that the condenser is aligned with the hole at the front of the counter.
- Slide out the baffle from the condenser housing and fix into position.
- Fix front grill supplied to front counter panel.

See page 10 for detail of grills.

Front Elevation of Counter

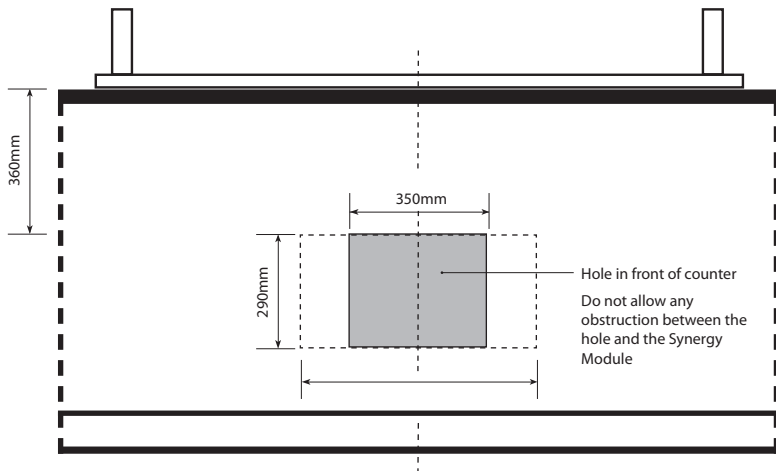

Front of Counter

- Cut a hole through the front of the counter as shown.
- Fit the small grill supplied over the aperture.
- The front panel (or the middle 800mm of it) must be removable to allow access for servicing.

Plan View of Counter

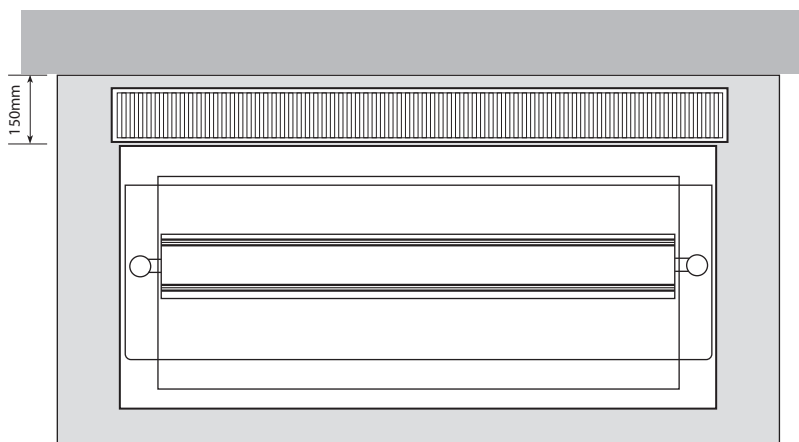

Counter Top

The hot exhaust air is vented up behind the back of the unit.

- You need a gap at least 150mm between the rear of the unit top and the wall. This can be left uncovered or the grill provided with customer facing control models can be fitted.
- Should you wish to use an alternative grill it must extend the full length of the unit and have an aperture area of at least 63%.
- Cool air refrigeration through the front grill.

REFRIGERATED VENTING - UNITS AGAINST A WALL METHOD 2

Air in the front out through the side

Not suitable for DRMT5 and DRMT25 multi-tier units

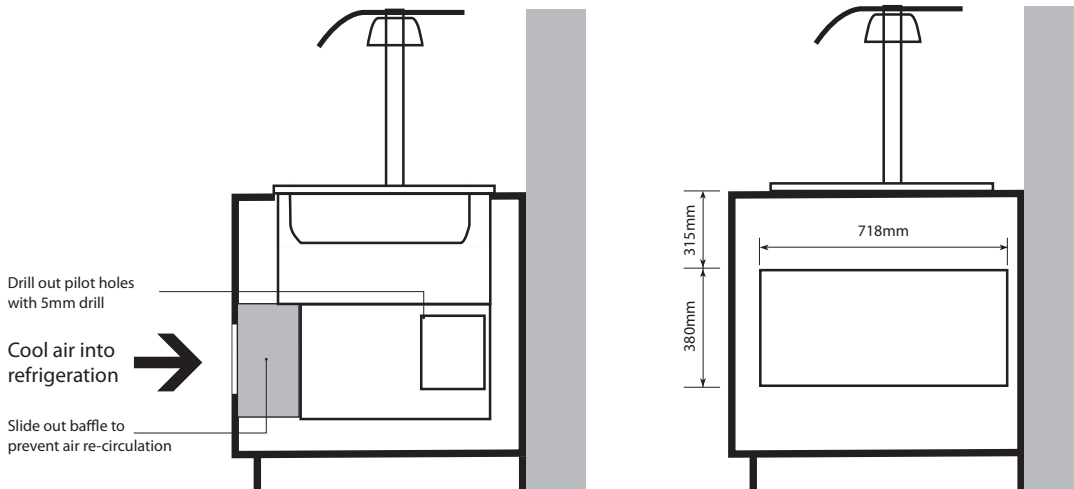

View with end panel removed

You can vent the exhaust air out of an open end of the counter or if possible both ends.

- To do this drill out the pilot holes in the side of the refrigeration system housing with a 5mm drill and remove panels.
- Panel off the rear of the refrigeration housing using a suitable material (*Not provided*).

View of end panel

End(s) of Counter

- Cut hole as indicated into the ends of the counter and fit suitable grill with a total aperture area of at least 0.17m²

Plan View of Counter

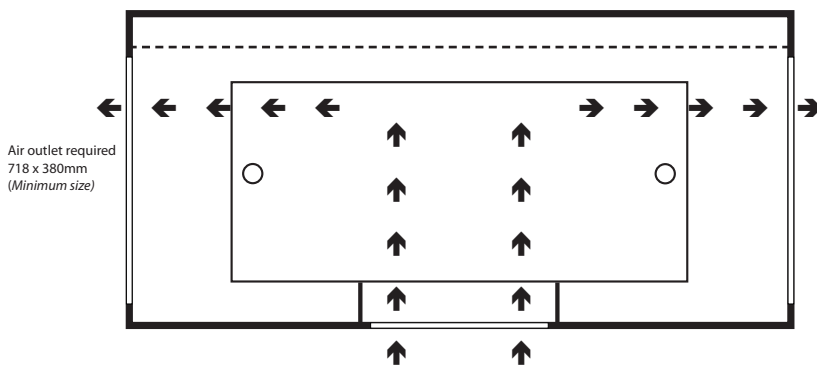

Front of Counter

- Cut a hole through the front of the counter as shown.
- Fit the small grill supplied over the aperture.
- The front panel (or the middle 800mm of it) must be removable to allow access for servicing.
- Slide out telescopic baffle to front of counter and fix into position.

Front Elevation of Counter

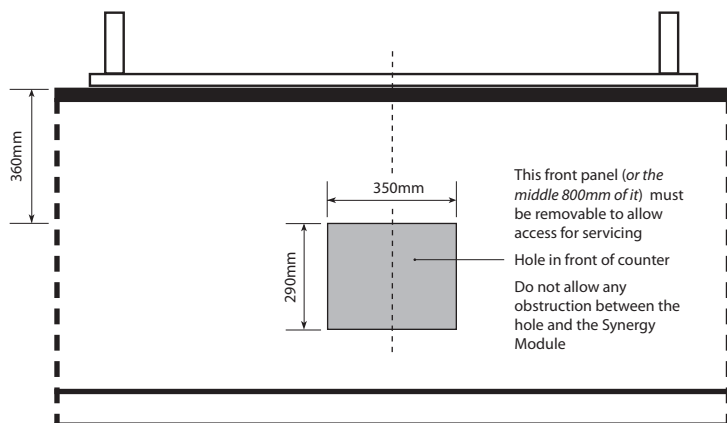

REFRIGERATED VENTING - VENTING FROM REAR

Air in and out of rear

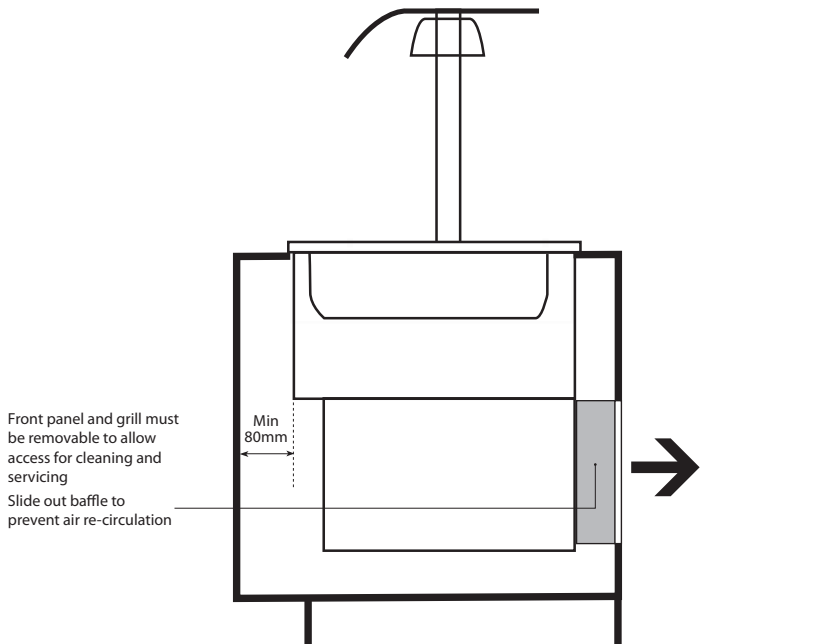

- For this method before dropping the unit into the counter you need to remove the telescopic baffle from the front of the refrigeration housing and place it in the rear of the housing
- To allow for sufficient air flow into the unit the cut out in the counter top needs to be atleast 80mm back from the front panel.
 - The front panel of the unit must be removable to allow for cleaning and servicing.

Front panel removable to allow access for cleaning and service.

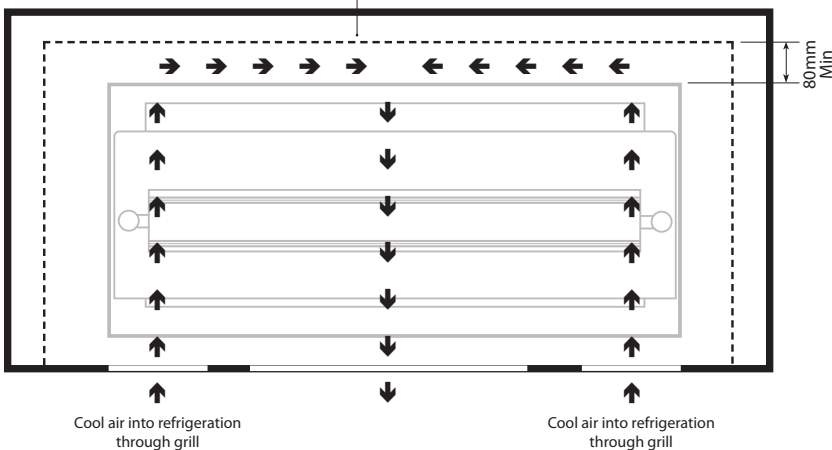

Rear of Counter

- The cut out for the air out is centrally positioned and must be 718mm x 380mm.
- Fit the large grill provided.
- The size of the air in cut-outs are dependant upon the size of the unit (see table below).
- Ensure that warm air (above 25°C) is not drawn into the unit.
- A minimum of 700mm is required behind the unit.
- The Inlet grills supplied are not suitable for this arrangement.
- Ensure that the transit brackets (if fitted) have been removed.

Grill must be removable for servicing

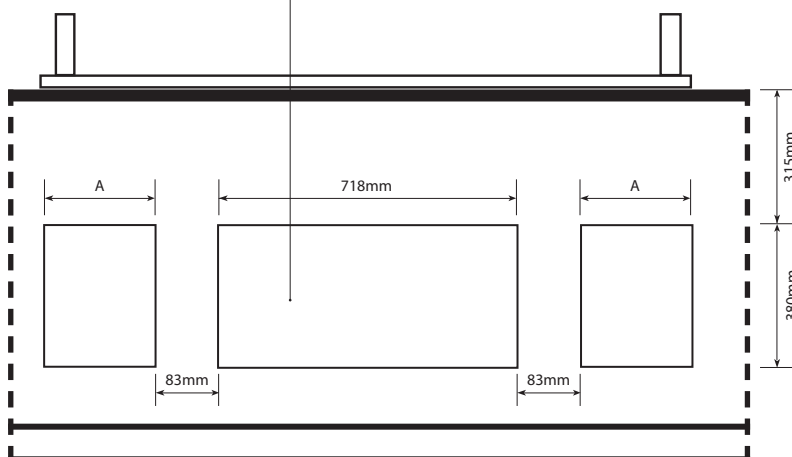

A	UNIT SIZE / TYPE
145mm	2 & 3 GN1/1 size wells, decks & delis
300mm	4 & 5 GN1/1 size wells, decks & delis
300mm	3 & 4 GN1/1 size multi-tiers
350mm	5 GN1/1 size multi-tiers

REFRIGERATED VENTING GRILLS

Standard front grill

Supplied with all refrigerated units to be fitted centrally to front of unit. The grill should be removable to allow regular cleaning of the condenser. Alternative grills detailed at the bottom of the page may be fitted instead. You may provide your own grill but to enable the unit to function correctly and to preserve the warranty it must have an open area of at least 0.041m² (0.09m² for 5 pan size multi-tier units)

Note a larger grill is supplied for DRMT5 & DRMT25

Dimensions:

550 x 330mm (482 x 269mm aperture)

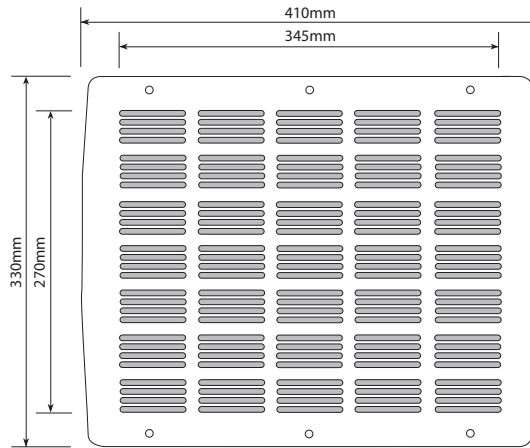

Standard rear grill

Supplied with all refrigerated units with operator facing controls, to be fitted centrally to the rear of unit. The grill should be removable to allow for servicing of the equipment. You may provide your own grill but to enable the unit to function correctly and to preserve the warranty it must have an open area of at least 0.17m².

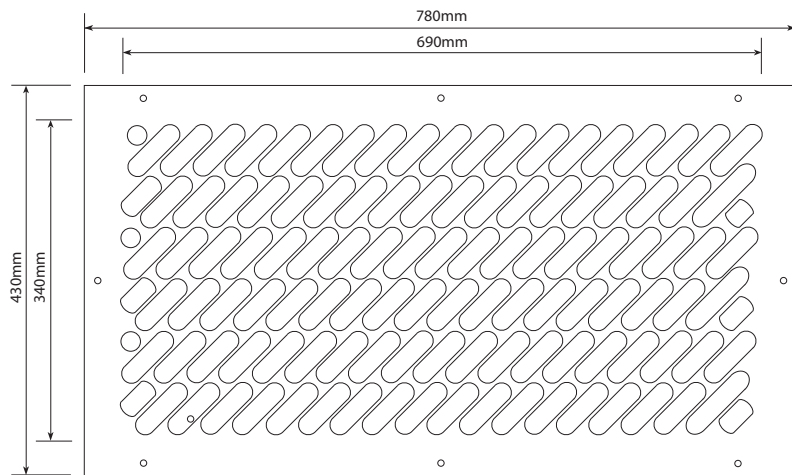

Alternative bright polished metal front grill

4 columns x 17 rows of

83mm x 12mm slots on a 17.5 mm pitch

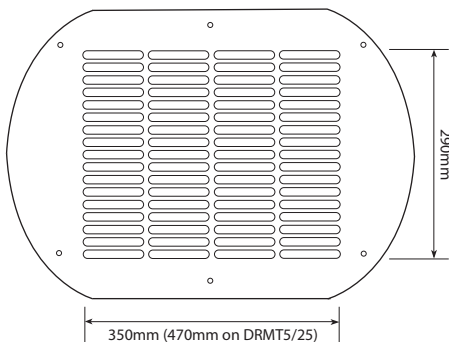

Alternative grill design to be routed into MDF/wood panels - must be removable

7 x 20mm wide slots on a 45mm pitch

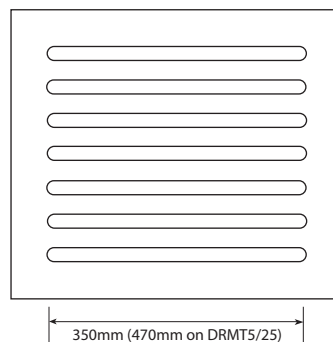

Grill supplied with units to be sited against a wall

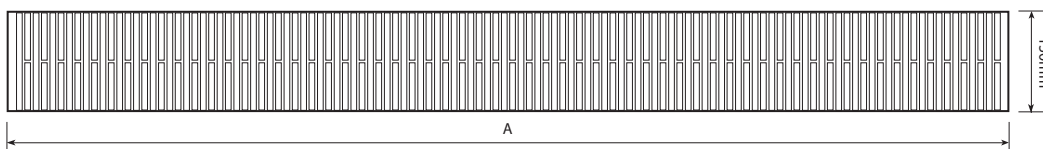

A	UNIT SIZE
850mm	2 pan
1176mm	3 pan
1503mm	4 pan
1830mm	5 pan

SPECIFICATIONS - CURVED GLASS HEATED

Heated units

Designed to maintain the temperature of hot food by providing heat from below, supplemented by quartz halogen heat lamps from above. Both top and lower heat levels are fully controllable. Controls are housed in the gantry hood to the operator side as standard. Model suffixed C the controls are on the customer side. For models without gantries controls are in a remote panel that mounts on the counter body within 1 metre of the unit.

Units below 3100W are fitted with 2 metres of cable and a 13 amp plug.

Units 3100W or over are supplied with 2 metres of cable and a 32 amp plug

Mains supply cables enter all units from the underneath to the left hand side of the unit (as view by the customer)

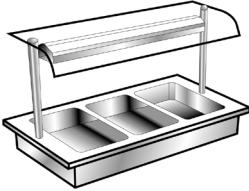

Heated Bains Marie - Dry heat 65mm deep well - controls to rear

Part No.	Cut out Size (mm)	Top Size (mm)	Power (kW)	Weight (kg)
DHBM2	725 x 636	850 x 660	1.5	45
DHBM3	1045 x 636	1177 x 660	2.4	60
DHBM4	1370 x 636	1504 x 660	3.0	75
DHBM5	1700 x 636	1831 x 660	3.9	90
DHBM6	2025 x 636	2158 x 660	4.8	100

Heated Bains Marie - Dry heat 65mm deep well - controls to front

Part No.	Cut out Size (mm)	Top Size (mm)	Power (kW)	Weight (kg)
DHBM2C	725 x 636	850 x 660	1.5	45
DHBM3C	1045 x 636	1177 x 660	2.4	60
DHBM4C	1370 x 636	1504 x 660	3.0	75
DHBM5C	1700 x 636	1831 x 660	3.9	90
DHBM6C	2025 x 636	2158 x 660	4.8	100

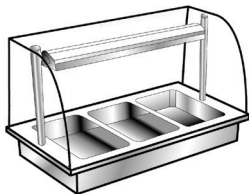
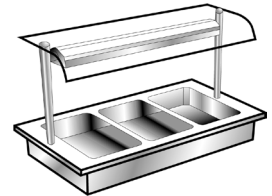

Heated Bains Marie - Dry heat 65mm deep well - enclosed

Part No.	Cut out Size (mm)	Top Size (mm)	Power (kW)	Weight (kg)
DHBM2E	725 x 636	850 x 660	1.5	60
DHBM3E	1045 x 636	1177 x 660	2.4	75
DHBM4E	1370 x 636	1504 x 660	3.0	90

Heated Bains Marie - Dry heat 150mm deep well - controls to rear

Part No.	Cut out Size (mm)	Top Size (mm)	Power (kW)	Weight (kg)
DHBD2	725 x 636	850 x 660	1.5	45
DHBD3	1045 x 636	1177 x 660	2.4	60
DHBD4	1370 x 636	1504 x 660	3.0	75
DHBD5	1700 x 636	1831 x 660	3.9	90
DHBD6	2025 x 636	2158 x 660	4.8	100

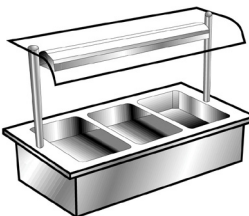
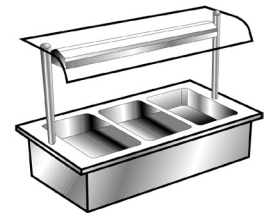

Heated Bains Marie - Dry heat 150mm deep well - controls to front

Part No.	Cut out Size (mm)	Top Size (mm)	Power (kW)	Weight (kg)
DHBD2C	725 x 636	850 x 660	1.5	45
DHBD3C	1045 x 636	1177 x 660	2.4	60
DHBD4C	1370 x 636	1504 x 660	3.0	75
DHBD5C	1700 x 636	1831 x 660	3.9	90
DHBD6C	2025 x 636	2158 x 660	4.8	100

SPECIFICATIONS - CURVED GLASS HEATED

Heated Bains Marie - Dry heat 150mm deep well - enclosed

Part No.	Cut out Size (mm)	Top Size (mm)	Power (kW)	Weight (kg)
DHBD2E	725 x 636	850 x 660	1.5	60
DHBD3E	1045 x 636	1177 x 660	2.4	75
DHBD4E	1370 x 636	1504 x 660	3.0	90

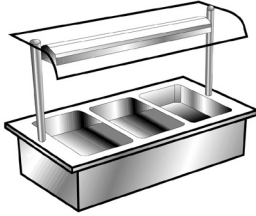
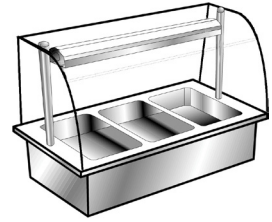

Heated Bains Marie - Wet or dry heat 150mm deep well - controls to rear

Part No.	Cut out Size (mm)	Top Size (mm)	Power (kW)	Weight (kg)
DHBW2	725 x 646	850 x 660	1.5	45
DHBW3	1045 x 646	1177 x 660	2.4	60
DHBW4	1370 x 646	1504 x 660	3.0	75
DHBW5	1700 x 646	1831 x 660	3.9	90

Heated Bains Marie - Wet or dry heat 150mm deep well - controls to front

Part No.	Cut out Size (mm)	Top Size (mm)	Power (kW)	Weight (kg)
DHBW2C	725 x 646	850 x 660	1.5	45
DHBW3C	1045 x 646	1177 x 660	2.4	60
DHBW4C	1370 x 646	1504 x 660	3.0	75
DHBW5C	1700 x 646	1831 x 660	3.9	90

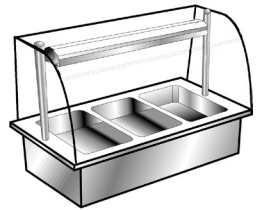
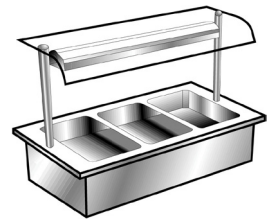

Heated Bains Marie - Wet or dry heat 150mm deep well - enclosed

Part No.	Cut out Size (mm)	Top Size (mm)	Power (kW)	Weight (kg)
DHBW2E	725 x 646	850 x 660	1.5	60
DHBW3E	1045 x 646	1177 x 660	2.4	75
DHBW4E	1370 x 646	1504 x 660	3.0	90

Heated ceramic hot plate - controls to rear

Part No.	Cut out Size (mm)	Top Size (mm)	Power (kW)	Weight (kg)
DHHP2	725 x 636	850 x 660	1.5	45
DHHP3	1045 x 636	1177 x 660	2.4	60
DHHP4	1370 x 636	1504 x 660	3.0	75
DHHP5	1700 x 636	1831 x 660	3.9	90
DHHP6	2025 x 636	2158 x 660	4.8	105

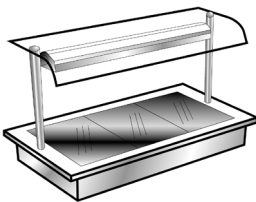
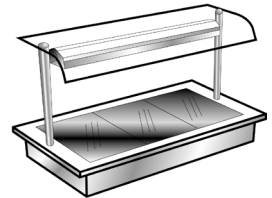

Heated ceramic hot plate - controls to front

Part No.	Cut out Size (mm)	Top Size (mm)	Power (kW)	Weight (kg)
DHHP2C	725 x 636	850 x 660	1.5	45
DHHP3C	1045 x 636	1177 x 660	2.4	60
DHHP4C	1370 x 636	1504 x 660	3.0	75
DHHP5C	1700 x 636	1831 x 660	3.9	90
DHHP6C	2025 x 636	2158 x 660	4.8	105

SPECIFICATIONS - CURVED GLASS HEATED

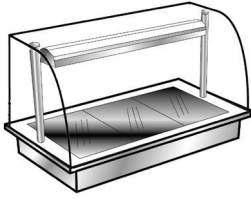

Heated ceramic hot plate - enclosed

Part No.	Cut out Size (mm)	Top Size (mm)	Power (kW)	Weight (kg)
DHHP2E	725 x 636	850 x 660	1.5	60
DHHP3E	1045 x 636	1177 x 660	2.4	75
DHHP4E	1370 x 636	1504 x 660	3.0	90

Heated recessed top - controls to rear

Part No.	Cut out Size (mm)	Top Size (mm)	Power (kW)	Weight (kg)
DHRT2	725 x 646	850 x 660	1.2	60
DHRT3	1045 x 646	1177 x 660	1.8	75
DHRT4	1370 x 646	1504 x 660	2.4	90
DHRT5	1700 x 646	1831 x 660	3.0	105

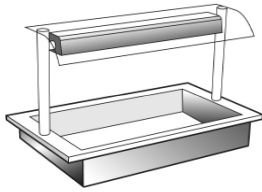
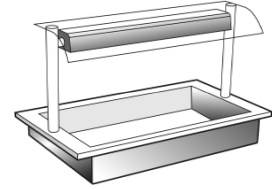

Heated recessed top - controls to front

Part No.	Cut out Size (mm)	Top Size (mm)	Power (kW)	Weight (kg)
DHRT2C	725 x 646	850 x 660	1.2	60
DHRT3C	1045 x 646	1177 x 660	1.8	75
DHRT4C	1370 x 646	1504 x 660	2.4	90
DHRT5C	1700 x 646	1831 x 660	3.0	105

Heated recessed top - enclosed

Part No.	Cut out Size (mm)	Top Size (mm)	Power (kW)	Weight (kg)
DHRT2E	725 x 646	850 x 660	1.2	75
DHRT3E	1045 x 646	1177 x 660	1.8	90
DHRT4E	1370 x 646	1504 x 660	2.4	105

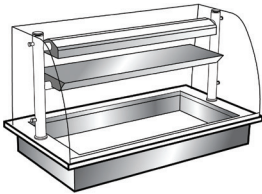
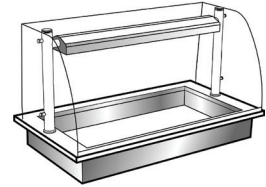

Heated display deli

Part No.	Cut out Size (mm)	Top Size (mm)	Power (kW)	Weight (kg)
DHDL2	725 x 646	850 x 660	1.4	85
DHDL3	1045 x 646	1177 x 660	2.1	100
DHDL4	1370 x 646	1504 x 660	2.8	115

SPECIFICATIONS - CURVED GLASS REFRIGERATED

Refrigerated units

Designed to maintain the temperature of pre-chilled food food - Refrigerated Units - Wells, Deck, Delis and drop-in Multi-tiers comply with the stringent requirements of EN ISO 23953 - 2:2005 Performance level M1 (-1°C to + 5°C) in Climate class 3 (25°C, 60%RH,0.2m/s) and Performance level M2 (-1°C to + 7°C) in Climate class 4 (30°C, 55%RH,0.2m/s)

Controls are housed in the gantry hood to the operator side as standard. Model suffixed C the controls are on the customer side. For models without gantries, controls are in a remote panel that mounts on the counter body within 1 metre of the unit.

Mains supply cables enter all units from the underneath to the lower left hand side of the refrigeration system housing unit (as viewed by the customer)

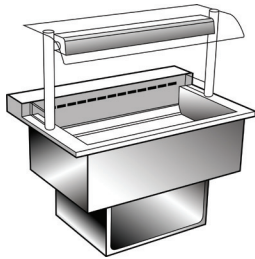

Refrigerated blown air deck - controls to rear

Part No.	Cut out Size (mm)	Top Size (mm)	Power (kW)	Weight (kg)
DRDK2	725 x 646	850 x 755	1.6	75
DRDK3	1045 x 646	1177 x 755	1.6	100
DRDK4	1370 x 646	1504 x 755	2.1	125
DRDK5	1700 x 646	1831 x 755	2.4	150

Refrigerated blown air deck - controls to front

Part No.	Cut out Size (mm)	Top Size (mm)	Power (kW)	Weight (kg)
DRDK2C	725 x 646	850 x 755	1.6	75
DRDK3C	1045 x 646	1177 x 755	1.6	100
DRDK4C	1370 x 646	1504 x 755	2.1	125
DRDK5C	1700 x 646	1831 x 755	2.4	150

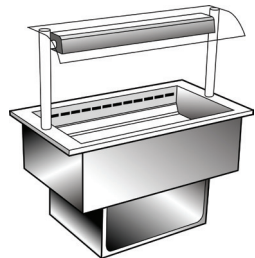
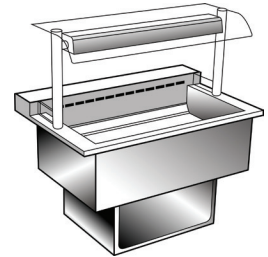

Refrigerated blown air well - controls to rear

Part No.	Cut out Size (mm)	Top Size (mm)	Power (kW)	Weight (kg)
DRWL2	725 x 646	850 x 660	1.6	75
DRWL3	1045 x 646	1177 x 660	1.6	100
DRWL4	1370 x 646	1504 x 660	2.1	125
DRWL5	1700 x 646	1831 x 660	2.4	150

Refrigerated blown air well - controls to front

Part No.	Cut out Size (mm)	Top Size (mm)	Power (kW)	Weight (kg)
DRWL2C	725 x 646	850 x 660	1.6	75
DRWL3C	1045 x 646	1177 x 660	1.6	100
DRWL4C	1370 x 646	1504 x 660	2.1	125
DRWL5C	1700 x 646	1831 x 660	2.4	150

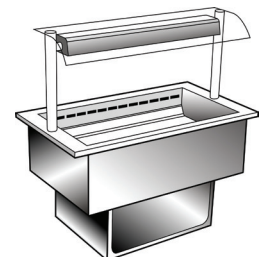

Refrigerated blown air well - enclosed

Part No.	Cut out Size (mm)	Top Size (mm)	Power (kW)	Weight (kg)
DRWL2E	725 x 646	850 x 660	1.6	90
DRWL3E	1045 x 646	1177 x 660	1.6	115
DRWL4E	1370 x 646	1504 x 660	2.1	140

Refrigerated island well

Part No.	Cut out Size (mm)	Top Size (mm)	Power (kW)	Weight (kg)
DRIW3	1045 x 646	1177 x 660	1.6	105
DRIW4	1370 x 646	1504 x 660	2.1	130

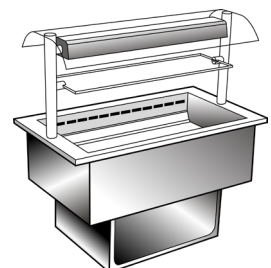

SPECIFICATIONS - CURVED GLASS REFRIGERATED

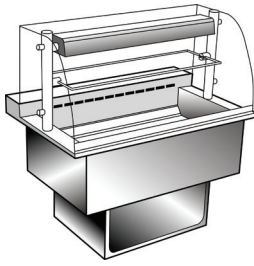

Refrigerated display deli

Part No.	Cut out Size (mm)	Top Size (mm)	Power (kW)	Weight (kg)
DRDL2	725 x 646	850 x 755	1.6	105
DRDL3	1045 x 646	1177 x 755	1.6	140
DRDL4	1370 x 646	1504 x 755	2.1	175

Refrigerated high deli

Part No.	Cut out Size (mm)	Top Size (mm)	Power (kW)	Weight (kg)
DRDH3	1045 x 646	1177 x 755	1.6	150
DRDH4	1370 x 646	1504 x 755	2.1	190

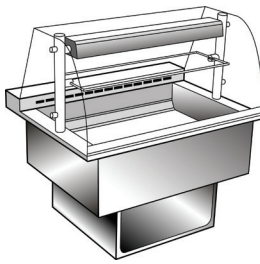
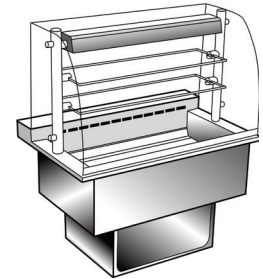

Refrigerated deep deli

Part No.	Cut out Size (mm)	Top Size (mm)	Power (kW)	Weight (kg)
DRDD2	725 x 796	850 x 905	1.6	110
DRDD3	1045 x 796	1177 x 905	1.6	150
DRDD4	1370 x 796	1504 x 905	2.1	190

Refrigerated three tier multi-deck - doors to rear

Part No.	Cut out Size (mm)	Top Size (mm)	Power (kW)	Weight (kg)
DRMT2	725 x 646	850 x 660	2.1	200
DRMT3	1045 x 646	1177 x 660	2.6	220
DRMT4	1370 x 646	1504 x 660	3.0	270
DRMT5	1700 x 646	1831 x 660	3.4	320

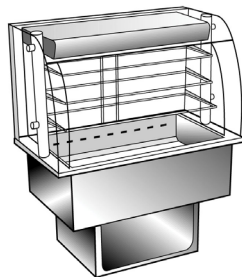
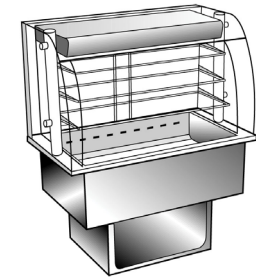

Refrigerated three tier multi-deck - solid back

Part No.	Cut out Size (mm)	Top Size (mm)	Power (kW)	Weight (kg)
DRMT2W	725 x 646	850 x 660	2.1	200
DRMT3W	1045 x 646	1177 x 660	2.6	220
DRMT4W	1370 x 646	1504 x 660	3.0	270
DRMT5W	1700 x 646	1831 x 660	3.4	320

Refrigerated two tier multi-deck - doors to rear

Part No.	Cut out Size (mm)	Top Size (mm)	Power (kW)	Weight (kg)
DRMT22	725 x 646	850 x 660	2.1	190
DRMT23	1045 x 646	1177 x 660	2.6	210
DRMT24	1370 x 646	1504 x 660	3.0	260
DRMT25	1700 x 646	1831 x 660	3.4	310

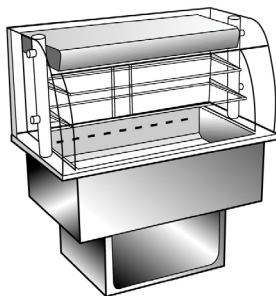
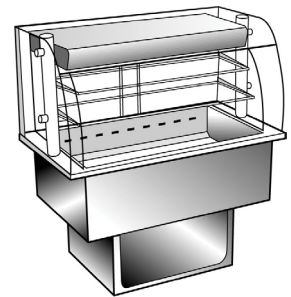

Refrigerated two tier multi-deck - solid back

Part No.	Cut out Size (mm)	Top Size (mm)	Power (kW)	Weight (kg)
DRMT22W	725 x 646	850 x 660	2.1	190
DRMT23W	1045 x 646	1177 x 660	2.6	210
DRMT24W	1370 x 646	1504 x 660	3.0	260
DRMT25W	1700 x 646	1831 x 660	3.4	310

SPECIFICATIONS - FLAT GLASS HEATED

Flat Glass - Heated units

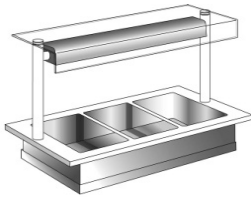

Heated Bains Marie - Dry heat 65mm deep well - controls to rear

Part No.	Cut out Size (mm)	Top Size (mm)	Power (kW)	Weight (kg)
SSHBM2	725 x 636	850 x 660	1.5	45
SSHBM3	1045 x 636	1177 x 660	2.4	60
SSHBM4	1370 x 636	1504 x 660	3.0	75
SSHBM5	1700 x 636	1831 x 660	3.9	90
SSHBM6	2025 x 636	2158 x 660	4.8	100

Heated Bains Marie - Dry heat 65mm deep well - controls to front

Part No.	Cut out Size (mm)	Top Size (mm)	Power (kW)	Weight (kg)
SSHBM2C	725 x 636	850 x 660	1.5	45
SSHBM3C	1045 x 636	1177 x 660	2.4	60
SSHBM4C	1370 x 636	1504 x 660	3.0	75
SSHBM5C	1700 x 636	1831 x 660	3.9	90
SSHBM6C	2025 x 636	2158 x 660	4.8	100

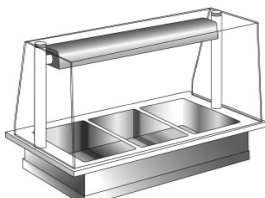
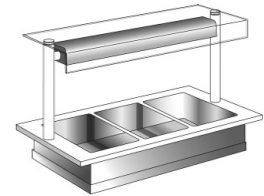

Heated Bains Marie - Dry heat 65mm deep well - enclosed

Part No.	Cut out Size (mm)	Top Size (mm)	Power (kW)	Weight (kg)
SFHBM2	725 x 636	850 x 660	1.5	60
SFHBM3	1045 x 636	1177 x 660	2.4	75
SFHBM4	1370 x 636	1504 x 660	3.0	90
SFHBM5	1700 x 636	1831 x 660	3.9	100
SFHBM6	2025 x 636	2158 x 660	4.8	115

Heated Bains Marie - Dry heat 150mm deep well - controls to rear

Part No.	Cut out Size (mm)	Top Size (mm)	Power (kW)	Weight (kg)
SSHBD2	725 x 636	850 x 660	1.5	45
SSHBD3	1045 x 636	1177 x 660	2.4	60
SSHBD4	1370 x 636	1504 x 660	3.0	75
SSHBD5	1700 x 636	1831 x 660	3.9	90
SSHBD6	2025 x 636	2158 x 660	4.8	100

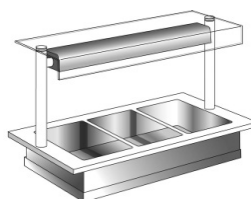
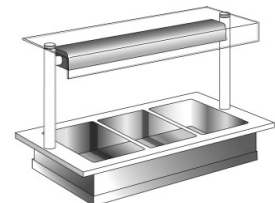

Heated Bains Marie - Dry heat 150mm deep well - controls to front

Part No.	Cut out Size (mm)	Top Size (mm)	Power (kW)	Weight (kg)
SSHBD2C	725 x 636	850 x 660	1.5	45
SSHBD3C	1045 x 636	1177 x 660	2.4	60
SSHBD4C	1370 x 636	1504 x 660	3.0	75
SSHBD5C	1700 x 636	1831 x 660	3.9	90
SSHBD6C	2025 x 636	2158 x 660	4.8	100

Heated Bains Marie - Dry heat 150mm deep well - enclosed

Part No.	Cut out Size (mm)	Top Size (mm)	Power (kW)	Weight (kg)
SFHBD2	725 x 636	850 x 660	1.5	60
SFHBD3	1045 x 636	1177 x 660	2.4	75
SFHBD4	1370 x 636	1504 x 660	3.0	90
SFHBD5	1700 x 636	1831 x 660	3.9	100
SFHBD6	2025 x 636	2158 x 660	4.8	115

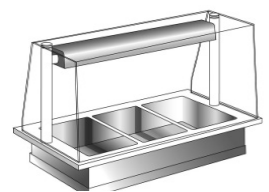

SPECIFICATIONS - FLAT GLASS HEATED

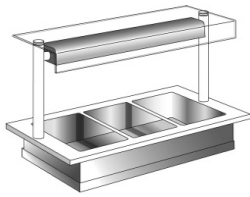

Heated Bains Marie - Wet or dry heat 150mm deep well - controls to rear

Part No.	Cut out Size (mm)	Top Size (mm)	Power (kW)	Weight (kg)
SSHBW2	725 x 646	850 x 660	1.5	45
SSHBW3	1045 x 646	1177 x 660	2.4	60
SSHBW4	1370 x 646	1504 x 660	3.0	75
SSHBW5	1700 x 646	1831 x 660	3.9	90

Heated Bains Marie - Wet or dry heat 150mm deep well - controls to front

Part No.	Cut out Size (mm)	Top Size (mm)	Power (kW)	Weight (kg)
SSHBW2C	725 x 646	850 x 660	1.5	45
SSHBW3C	1045 x 646	1177 x 660	2.4	60
SSHBW4C	1370 x 646	1504 x 660	3.0	75
SSHBW5C	1700 x 646	1831 x 660	3.9	90

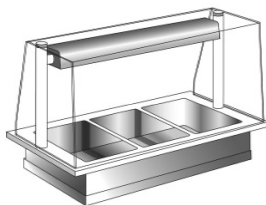
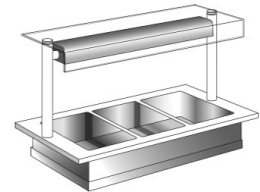

Heated Bains Marie - Wet or dry heat 150mm deep well - enclosed

Part No.	Cut out Size (mm)	Top Size (mm)	Power (kW)	Weight (kg)
SFHBW2	725 x 646	850 x 660	1.5	60
SFHBW3	1045 x 646	1177 x 660	2.4	75
SFHBW4	1370 x 646	1504 x 660	3.0	90
SFHBW5	1700 x 646	1831 x 660	3.9	100

Heated ceramic hot plate - controls to rear

Part No.	Cut out Size (mm)	Top Size (mm)	Power (kW)	Weight (kg)
SSHHP2	725 x 636	850 x 660	1.5	45
SSHHP3	1045 x 636	1177 x 660	2.4	60
SSHHP4	1370 x 636	1504 x 660	3.0	75
SSHHP5	1700 x 636	1831 x 660	3.9	90
SSHHP6	2025 x 636	2158 x 660	4.8	100

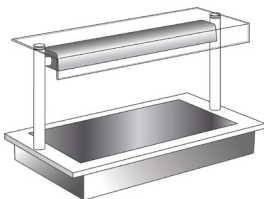
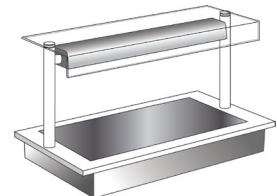

Heated ceramic hot plate - controls to front

Part No.	Cut out Size (mm)	Top Size (mm)	Power (kW)	Weight (kg)
SSHHP2C	725 x 636	850 x 660	1.5	45
SSHHP3C	1045 x 636	1177 x 660	2.4	60
SSHHP4C	1370 x 636	1504 x 660	3.0	75
SSHHP5C	1700 x 636	1831 x 660	3.9	90
SSHHP6C	2025 x 636	2158 x 660	4.8	100

Heated ceramic hot plate - controls to rear - enclosed

Part No.	Cut out Size (mm)	Top Size (mm)	Power (kW)	Weight (kg)
SFHHP2	725 x 636	850 x 660	1.5	60
SFHHP3	1045 x 636	1177 x 660	2.4	75
SFHHP4	1370 x 636	1504 x 660	3.0	90
SFHHP5	1700 x 636	1831 x 660	3.9	100
SFHHP6	2025 x 636	2158 x 660	4.8	115

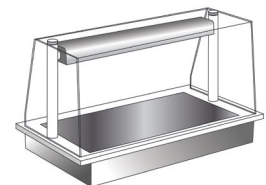

SPECIFICATIONS - FLAT GLASS HEATED & REFRIGERATED

Flat Glass - Heated & Refrigerated units

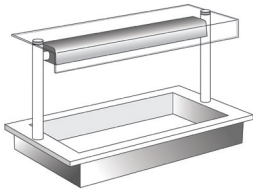

Heated recessed top - controls to rear

Part No.	Cut out Size (mm)	Top Size (mm)	Power (kW)	Weight (kg)
SSHRT2	725 x 646	850 x 660	1.5	45
SSHRT3	1045 x 646	1177 x 660	2.4	60
SSHRT4	1370 x 646	1504 x 660	3.0	75
SSHRT5	1700 x 646	1831 x 660	3.9	90

Heated recessed top - controls to front

Part No.	Cut out Size (mm)	Top Size (mm)	Power (kW)	Weight (kg)
SSHRT2C	725 x 646	850 x 660	1.5	45
SSHRT3C	1045 x 646	1177 x 660	2.4	60
SSHRT4C	1370 x 646	1504 x 660	3.0	75
SSHRT5C	1700 x 646	1831 x 660	3.9	90

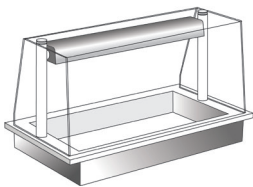
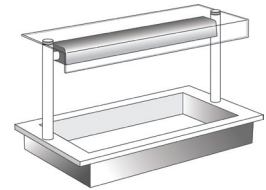

Heated recessed top - controls to rear - enclosed

Part No.	Cut out Size (mm)	Top Size (mm)	Power (kW)	Weight (kg)
SFHRT2	725 x 646	850 x 660	1.5	60
SFHRT3	1045 x 646	1177 x 660	2.4	75
SFHRT4	1370 x 646	1504 x 660	3.0	90
SFHRT5	1700 x 646	1831 x 660	3.9	100

Heated display deli

Part No.	Cut out Size (mm)	Top Size (mm)	Power (kW)	Weight (kg)
SFHDL2	725 x 646	850 x 660	1.4	70
SFHDL3	1045 x 646	1177 x 660	2.1	85
SFHDL4	1370 x 646	1504 x 660	2.8	100

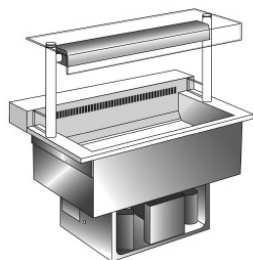
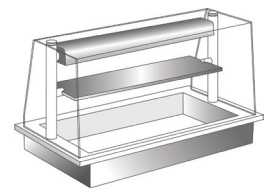

Refrigerated blown air deck - controls to rear

Part No.	Cut out Size (mm)	Top Size (mm)	Power (kW)	Weight (kg)
SSRDK2	725 x 646	850 x 775	1.6	75
SSRDK3	1045 x 646	1177 x 775	1.6	100
SSRDK4	1370 x 646	1504 x 775	2.1	125
SSRDK5	1700 x 646	1831 x 775	2.4	150

Refrigerated blown air deck - controls to front

Part No.	Cut out Size (mm)	Top Size (mm)	Power (kW)	Weight (kg)
SSRDK2C	725 x 646	850 x 660	1.6	75
SSRDK3C	1045 x 646	1177 x 660	1.6	100
SSRDK4C	1370 x 646	1504 x 660	2.1	125
SSRDK5C	1700 x 646	1831 x 660	2.4	150

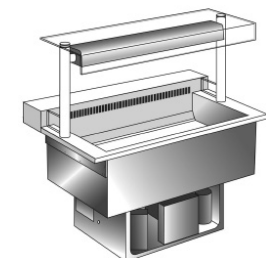

SPECIFICATIONS - FLAT GLASS REFRIGERATED

Flat Glass - Refrigerated units

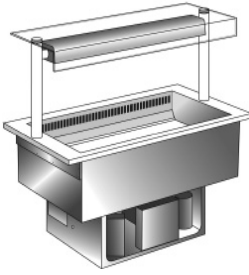

Refrigerated blown air well - controls to rear

Part No.	Cut out Size (mm)	Top Size (mm)	Power (kW)	Weight (kg)
SSRWL2	725 x 646	850 x 660	1.6	75
SSRWL3	1045 x 646	1177 x 660	1.6	100
SSRWL4	1370 x 646	1504 x 660	2.1	125
SSRWL5	1700 x 646	1831 x 660	2.4	150

Refrigerated blown air well - controls to front

Part No.	Cut out Size (mm)	Top Size (mm)	Power (kW)	Weight (kg)
SSRWL2C	725 x 646	850 x 660	1.6	75
SSRWL3C	1045 x 646	1177 x 660	1.6	100
SSRWL4C	1370 x 646	1504 x 660	2.1	125
SSRWL5C	1700 x 646	1831 x 660	2.4	150

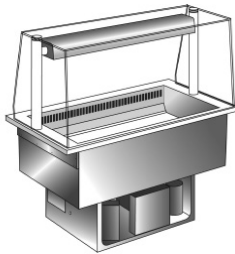
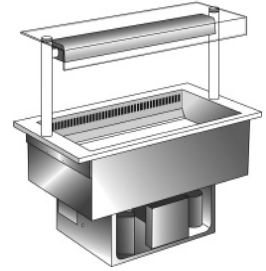

Refrigerated blown air well - controls to rear - enclosed

Part No.	Cut out Size (mm)	Top Size (mm)	Power (kW)	Weight (kg)
SFRWL2	725 x 646	850 x 660	1.6	90
SFRWL3	1045 x 646	1177 x 660	1.6	115
SFRWL4	1370 x 646	1504 x 660	2.1	140
SFRWL5	1700 x 646	1831 x 660	2.4	165

Refrigerated island well

Part No.	Cut out Size (mm)	Top Size (mm)	Power (kW)	Weight (kg)
SSRIW3	1045 x 646	1177 x 660	1.6	105
SSRIW4	1370 x 646	1504 x 660	2.1	130
SSRIW5	1700 x 646	1831 x 660	2.4	155

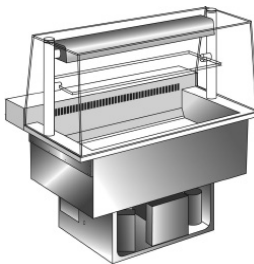
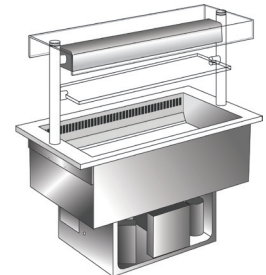

Refrigerated display deli

Part No.	Cut out Size (mm)	Top Size (mm)	Power (kW)	Weight (kg)
SFRDL2	725 x 646	850 x 755	1.6	105
SFRDL3	1045 x 646	1177 x 755	1.6	140
SFRDL4	1370 x 646	1504 x 755	2.1	175
SFRDL5	1700 x 646	1831 x 755	2.4	200

Refrigerated three tier multi-deck - doors to rear

Part No.	Cut out Size (mm)	Top Size (mm)	Power (kW)	Weight (kg)
SSRMT3	1045 x 646	1177 x 660	2.6	220
SSRMT4	1370 x 646	1504 x 660	3.0	270
SSRMT5	1700 x 646	1831 x 660	3.4	320

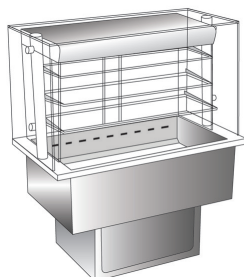
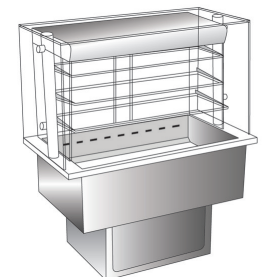

Refrigerated three tier multi-deck - solid back

Part No.	Cut out Size (mm)	Top Size (mm)	Power (kW)	Weight (kg)
SSRMT3W	1045 x 646	1177 x 660	2.6	220
SSRMT4W	1370 x 646	1504 x 660	3.0	270
SSRMT5W	1700 x 646	1831 x 660	3.4	320

SPECIFICATIONS - FLAT GLASS REFRIGERATED

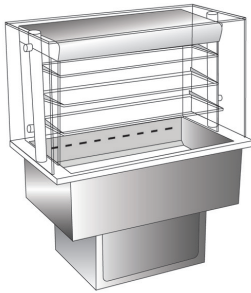

Refrigerated two tier multi-deck - doors to rear

Part No.	Cut out Size (mm)	Top Size (mm)	Power (kW)	Weight (kg)
SSRMT23	1045 x 646	1177 x 660	2.6	210
SSRMT24	1370 x 646	1504 x 660	3.0	260
SSRMT25	1700 x 646	1831 x 660	3.4	310

Refrigerated two tier multi-deck - solid back

Part No.	Cut out Size (mm)	Top Size (mm)	Power (kW)	Weight (kg)
SSRMT23W	1045 x 646	1177 x 660	2.6	210
SSRMT24W	1370 x 646	1504 x 660	3.0	260
SSRMT25W	1700 x 646	1831 x 660	3.4	310

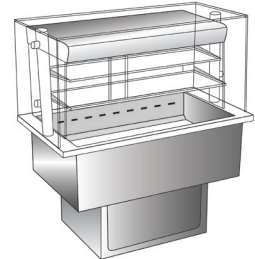

SPECIFICATIONS - NO GANTRY

Ancillary units

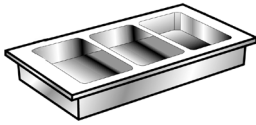

Heated Bains Marie - Dry heat 65mm deep well - no gantry

Part No.	Cut out Size (mm)	Top Size (mm)	Power (kW)	Weight (kg)
WDHBM2	725 x 636	850 x 660	0.9	30
WDHBM3	1045 x 636	1177 x 660	1.5	45
WDHBM4	1370 x 636	1504 x 660	1.8	60
WDHBM5	1700 x 636	1831 x 660	2.4	75
WDHBM6	2025 x 636	2158 x 660	3.0	90

Heated Bains Marie - Dry heat 150mm deep well - no gantry

Part No.	Cut out Size (mm)	Top Size (mm)	Power (kW)	Weight (kg)
WDHBD2	725 x 636	850 x 660	0.9	30
WDHBD3	1045 x 636	1177 x 660	1.5	45
WDHBD4	1370 x 636	1504 x 660	1.8	60
WDHBD5	1700 x 636	1831 x 660	2.4	75
WDHBD6	2025 x 636	2158 x 660	3.0	90

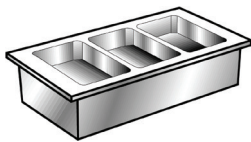
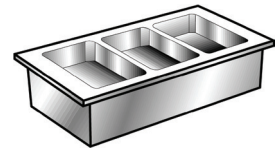

Heated Bains Marie - Wet or dry heat 150mm deep well - no gantry

Part No.	Cut out Size (mm)	Top Size (mm)	Power (kW)	Weight (kg)
WDHBW2	725 x 646	850 x 660	0.9	30
WDHBW3	1045 x 646	1177 x 660	1.5	45
WDHBW4	1370 x 646	1504 x 660	1.8	60
WDHBW5	1700 x 646	1831 x 660	2.4	75

Heated ceramic hot plate - no gantry

Part No.	Cut out Size (mm)	Top Size (mm)	Power (kW)	Weight (kg)
WDHHP2	725 x 636	850 x 660	0.9	30
WDHHP3	1045 x 636	1177 x 660	1.5	45
WDHHP4	1370 x 636	1504 x 660	1.8	60
WDHHP5	1700 x 636	1831 x 660	2.4	75
WDHHP6	2025 x 636	2158 x 660	3.0	95

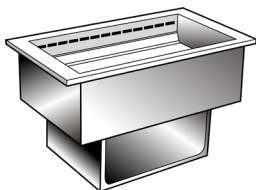
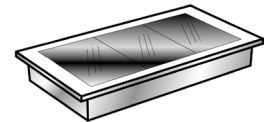

Refrigerated blown air well - no gantry, supplied with control box

Part No.	Cut out Size (mm)	Top Size (mm)	Power (kW)	Weight (kg)
WDRWL2	725 x 646	850 x 660	1.6	60
WDRWL3	1045 x 646	1177 x 660	1.6	85
WDRWL4	1370 x 646	1504 x 660	2.1	110
WDRWL5	1700 x 646	1831 x 660	2.4	130

Ambient cutlery & condiment unit

Part No.	Cut out Size (mm)	Top Size (mm)	Power (kW)	Weight (kg)
DRAC2	725 x 636	900 x 660	-	30
DRAC3	1045 x 636	1252 x 660	-	35

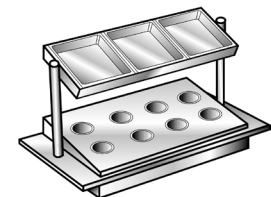

SPECIFICATIONS - ANCILLARY

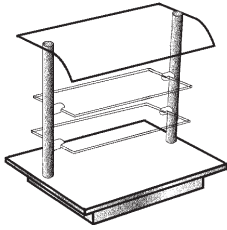

Glass shelf display unit

Part No.	Cut out Size (mm)	Top Size (mm)	Power (kW)	Weight (kg)
DRAG2	725 x 636	850 x 660	0.2	45



Wire shelf display unit

Part No.	Cut out Size (mm)	Top Size (mm)	Power (kW)	Weight (kg)
DRAW2	725 x 636	850 x 660	0.2	45

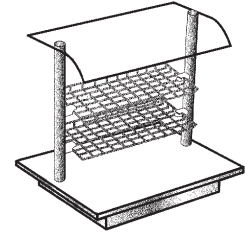

Soup Well

Part No.	Cut out Dia (mm)	Flange (mm)	Depth (mm)	Power (kW)
DHSS2	300	360 x 330	260	1.37

Plate dispensers

Part No.	Cut out Dia (mm)	Flange Dia (mm)	Depth (mm)	Power (kW)
72-0315	342	359	660	-
70-0190	370	382	660	-
72-0320	342	359	670	0.4
72-0325	370	382	670	0.4

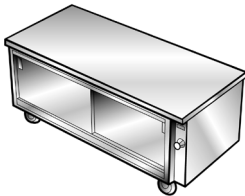
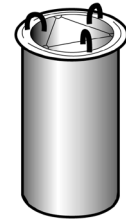

Roll under hot cupboards

Part No.	Dimensions (mm)	Power (kW)
ROLLHOT10	1000 x 700 x 700	1.0
ROLLHOT12	1175 x 700 x 700	1.0
ROLLHOT15	1525 x 700 x 700	2.0
ROLLHOT18	1825 x 700 x 700	2.0

Slide under heated drawers

Part No.	Dimensions (mm)	Power (kW)
HD75RU2	760 x 650 x 655	1.5

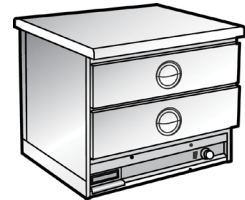

DIMENSIONS - DHHP, SSHHP, DHBM, SSHBM

Ceramic hot plate / Bains marie (Measurements in mm)

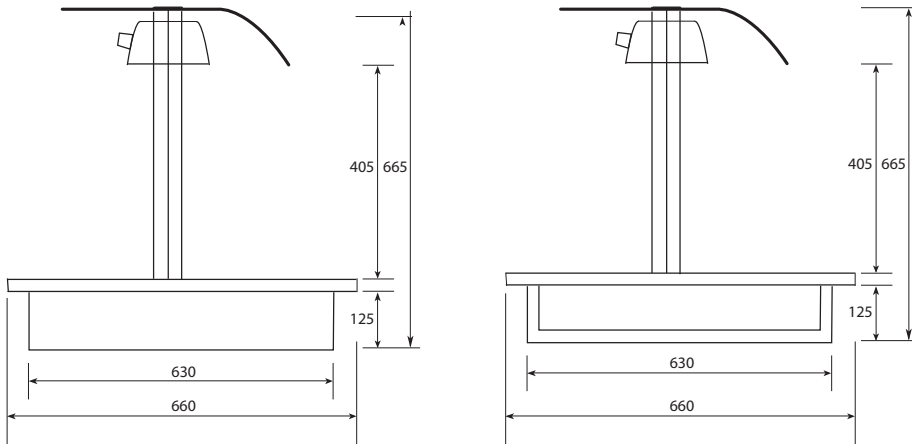

G/N CAPACITY 1
CUT-OUT SIZE 430 x 636

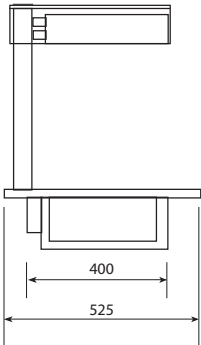

G/N CAPACITY 2
CUT-OUT SIZE 725 x 636

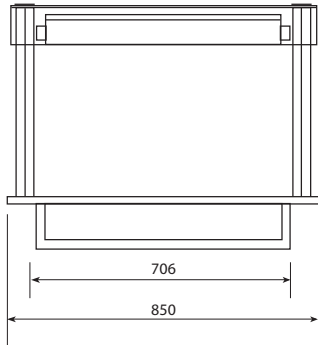

G/N CAPACITY 3
CUT-OUT SIZE 1045 x 636

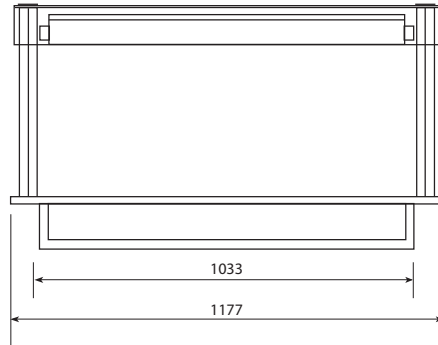

G/N CAPACITY 4
CUT-OUT SIZE 1370 x 636

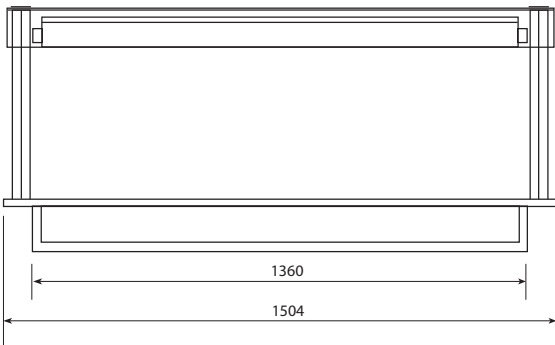

G/N CAPACITY 5
CUT-OUT SIZE 1700 x 636

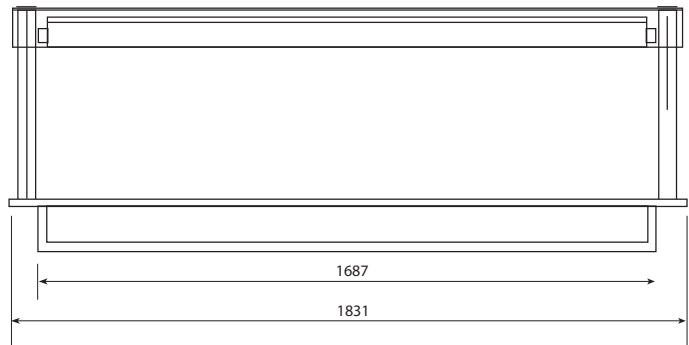

G/N CAPACITY 6
CUT-OUT SIZE 2025 x 636

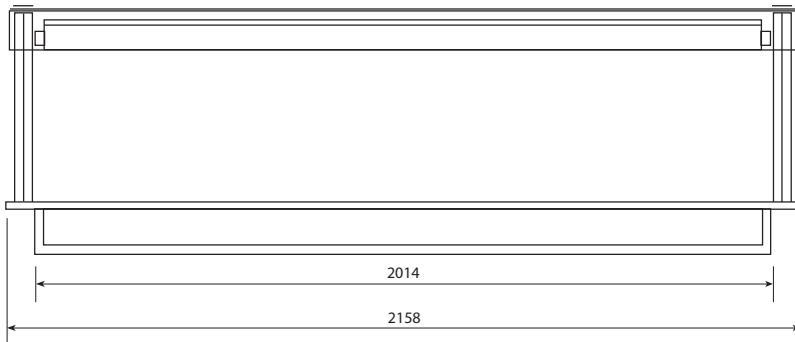

AutoCAD blocks can be downloaded from www.victoronline.co.uk

DIMENSIONS - DHBD, SSHBD, SFHBD

Bains marie (Measurements in mm)

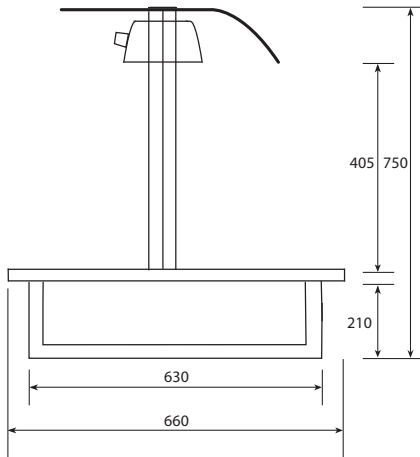

G/N CAPACITY 2
CUT-OUT SIZE 725 x 636

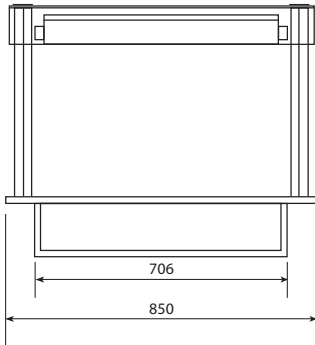

G/N CAPACITY 3
CUT-OUT SIZE 1045 x 636

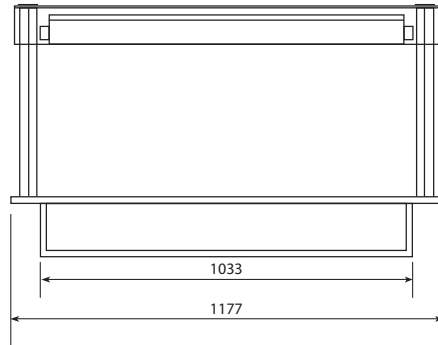

G/N CAPACITY 4
CUT-OUT SIZE 1370 x 636

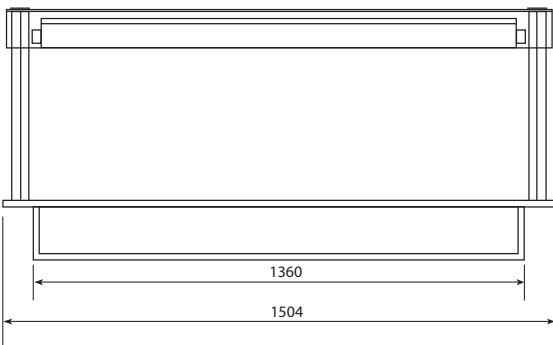

G/N CAPACITY 5
CUT-OUT SIZE 1700 x 636

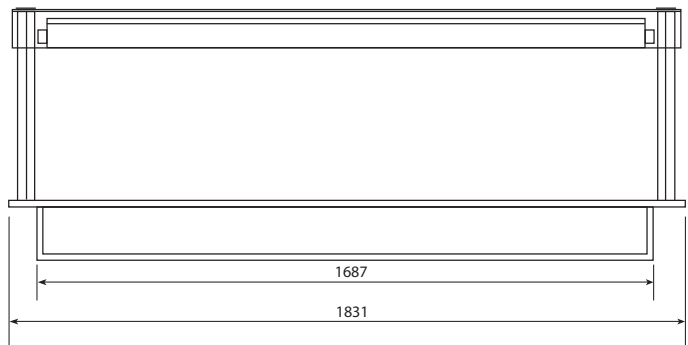

G/N CAPACITY 6
CUT-OUT SIZE 2025 x 636

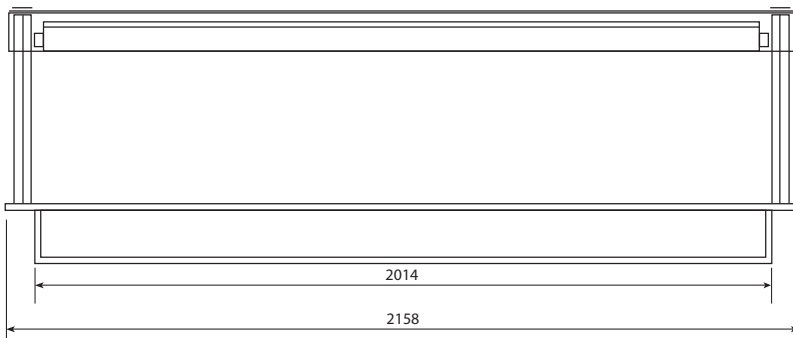

AutoCAD blocks can be downloaded from www.victoronline.co.uk

DIMENSIONS - DHBW, SSHBW, SFHBW

Bains marie (Measurements in mm)

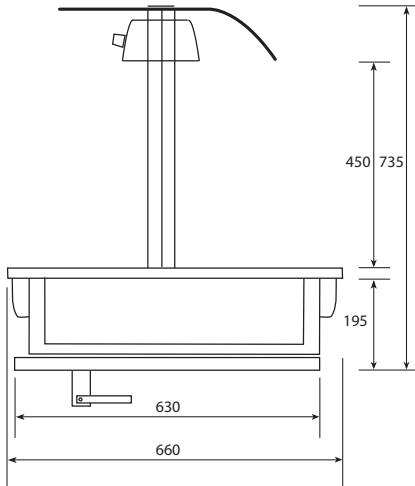

G/N CAPACITY 2
CUT-OUT SIZE 725 x 646

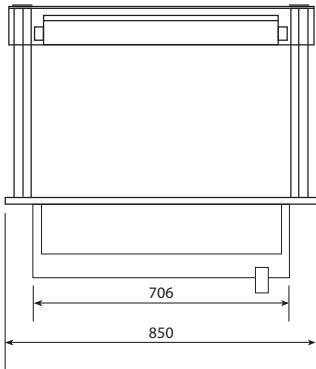

G/N CAPACITY 3
CUT-OUT SIZE 1045 x 646

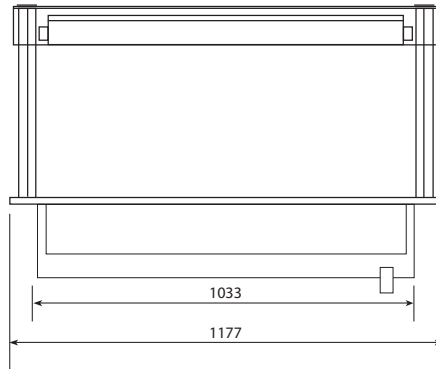

G/N CAPACITY 4
CUT-OUT SIZE 1370 x 646

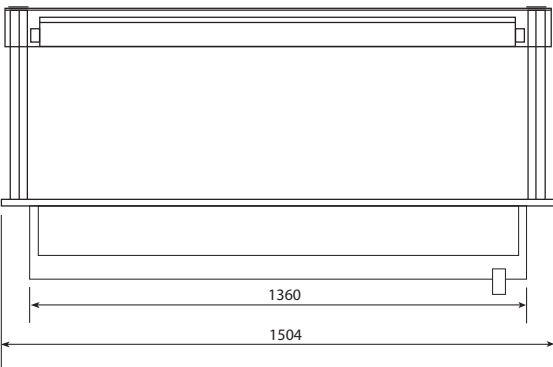

G/N CAPACITY 5
CUT-OUT SIZE 1700 x 646

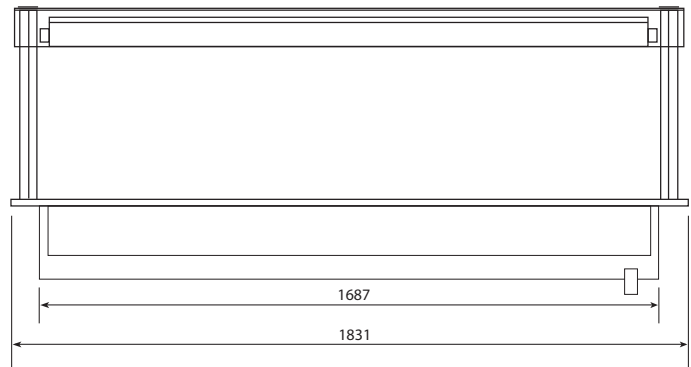

AutoCAD blocks can be downloaded from www.victoronline.co.uk

DIMENSIONS - SSHRT, SFHRT, DHDL, SFHDL

Recessed well / Heated deli (Measurements in mm)

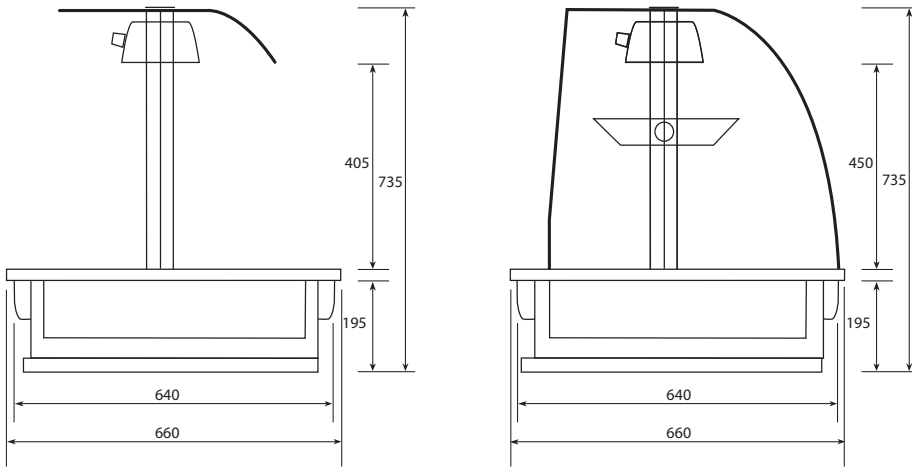

G/N CAPACITY 2
CUT-OUT SIZE 725 x 646

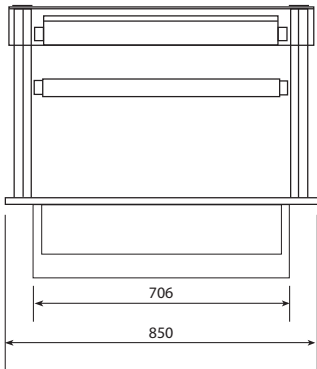

G/N CAPACITY 3
CUT-OUT SIZE 1045 x 646

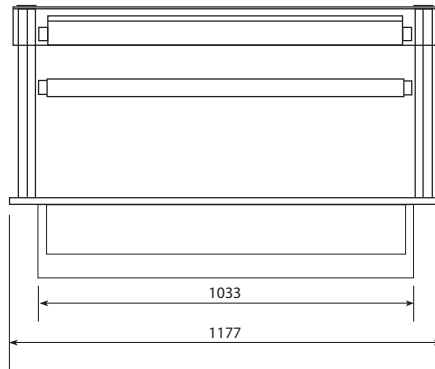

G/N CAPACITY 4
CUT-OUT SIZE 1370 x 646

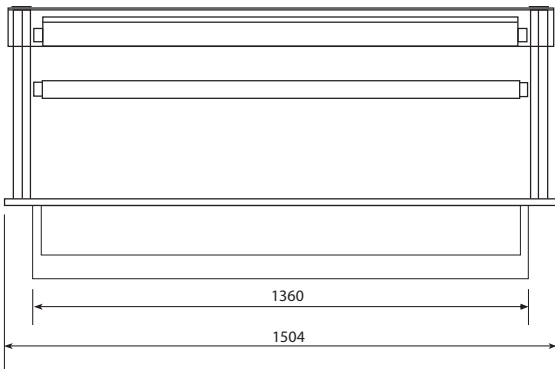

G/N CAPACITY 5
CUT-OUT SIZE 1700 x 646

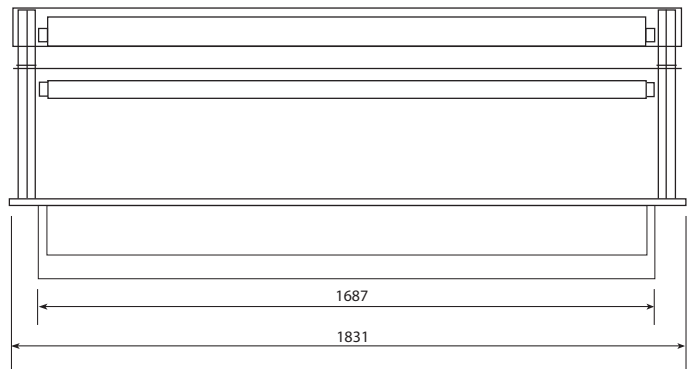

AutoCAD blocks can be downloaded from www.victoronline.co.uk

DIMENSIONS - DRWL, DRIW, SSRWL, SFRWL, SSRIW

Blown air wells / Island wells (Measurements in mm)

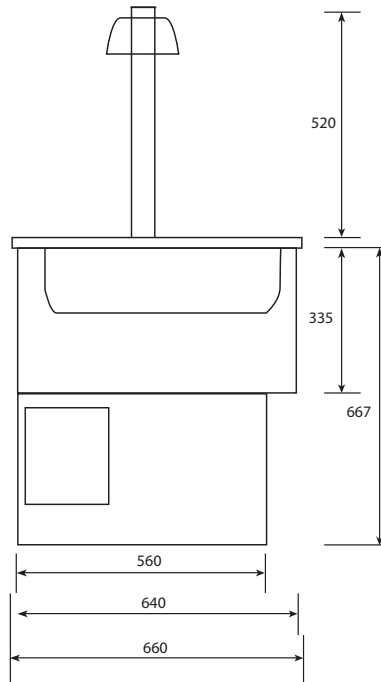
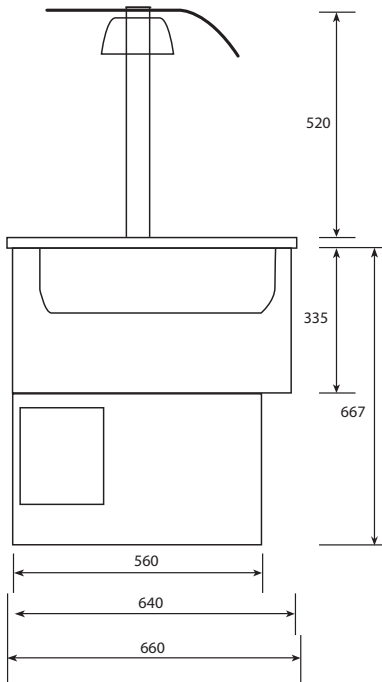

G/N CAPACITY 2
CUT-OUT SIZE 725 x 646

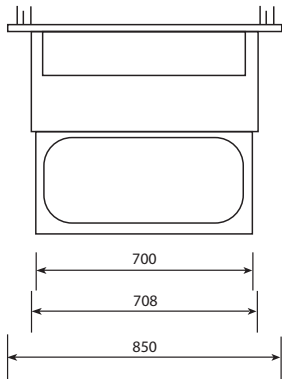

G/N CAPACITY 3
CUT-OUT SIZE 1045 x 646

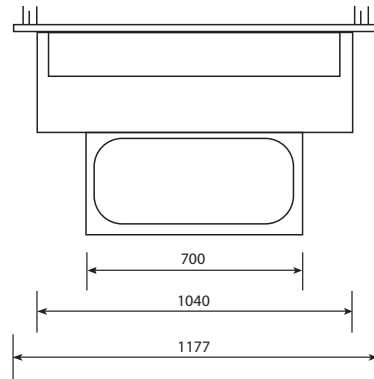

G/N CAPACITY 4
CUT-OUT SIZE 1370 x 646

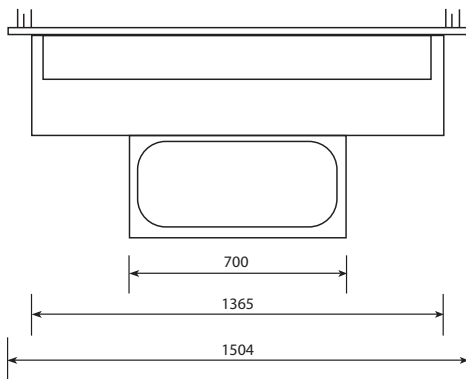

G/N CAPACITY 5
CUT-OUT SIZE 1700 x 646

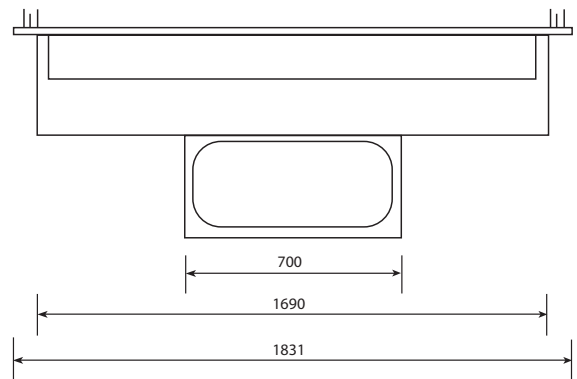

AutoCAD blocks can be downloaded from www.victoronline.co.uk

DIMENSIONS - DRDK, SSRDK, DRDL, SFRDL

Blown air deck / Display deli (Measurements in mm)

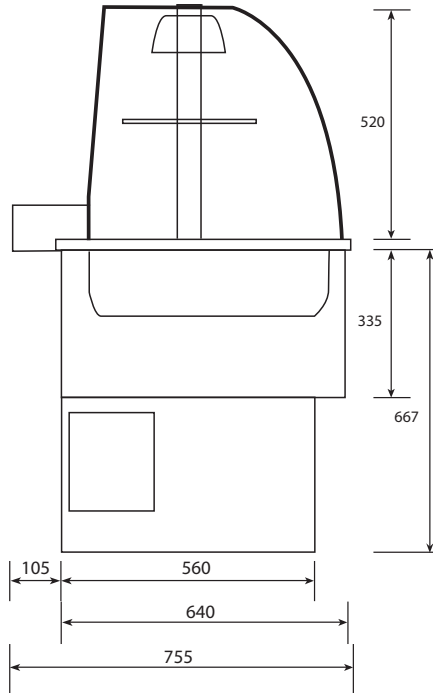
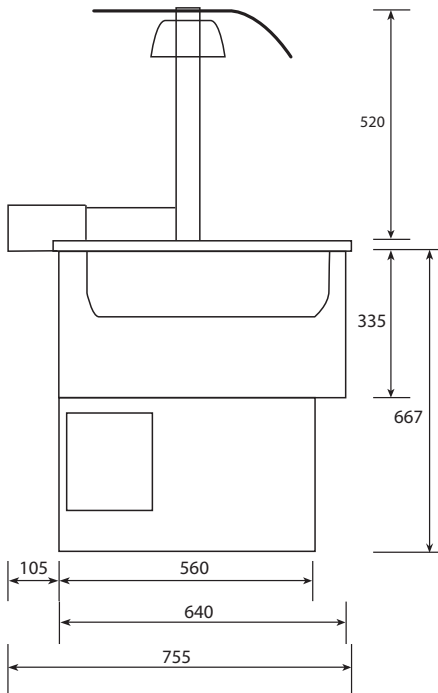

G/N CAPACITY 2
CUT-OUT SIZE 725 x 646

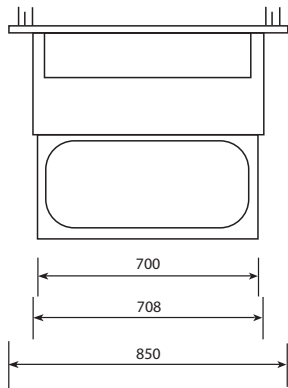

G/N CAPACITY 3
CUT-OUT SIZE 1045 x 646

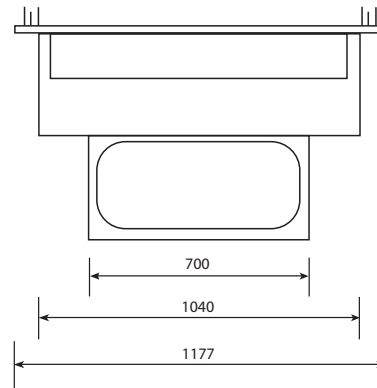

G/N CAPACITY 4
CUT-OUT SIZE 1370 x 646

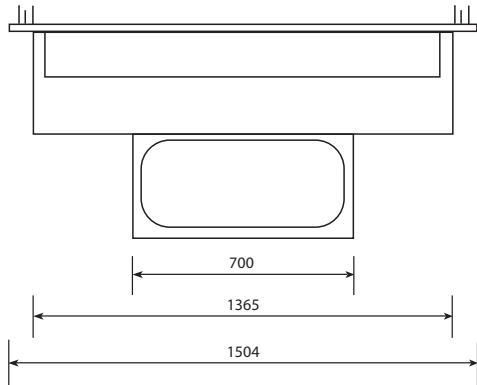

G/N CAPACITY 5
CUT-OUT SIZE 1700 x 646

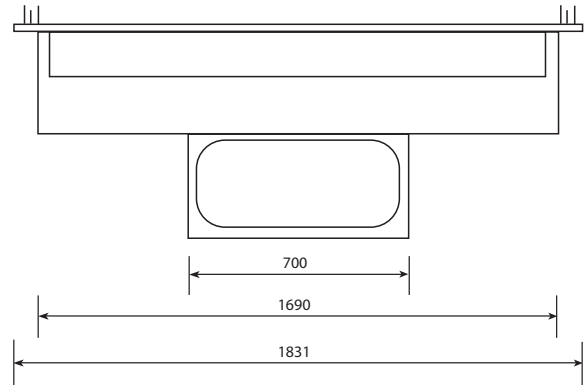

AutoCAD blocks can be downloaded from www.victoronline.co.uk

DIMENSIONS - DRDD, DHDH

Deep deli / High deli (Measurements in mm)

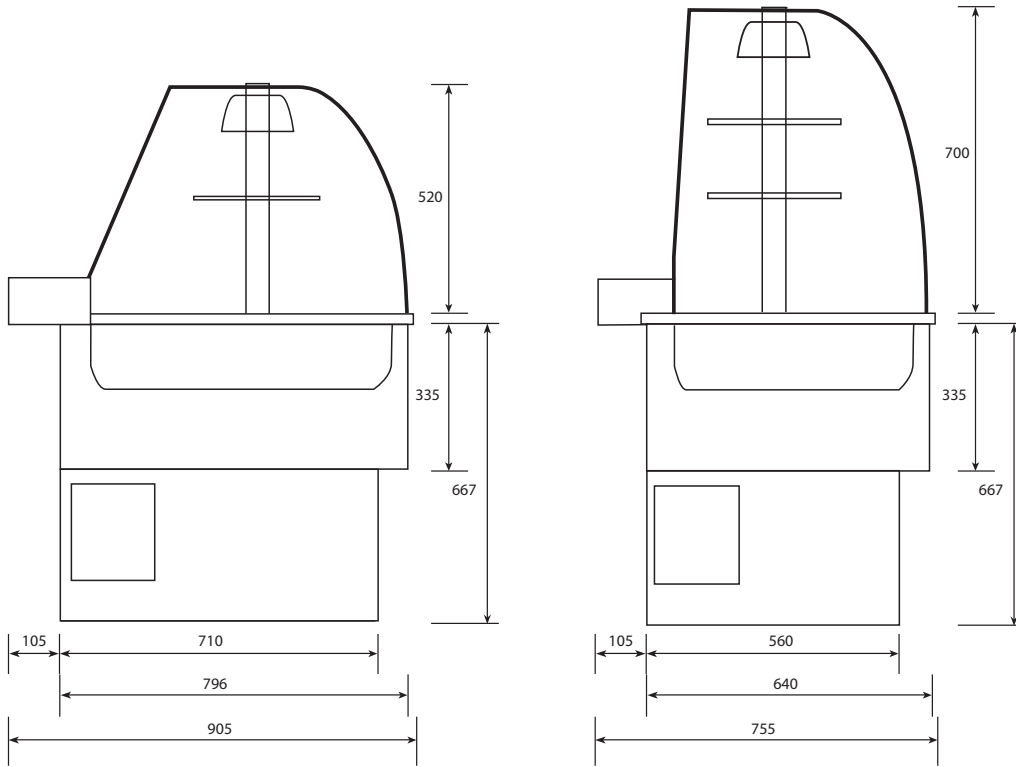

G/N CAPACITY 2
CUT-OUT SIZE 725 x 646/796

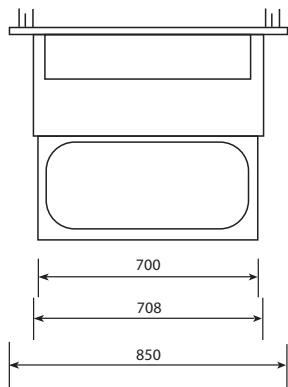

G/N CAPACITY 3
CUT-OUT SIZE 1045 x 646/796

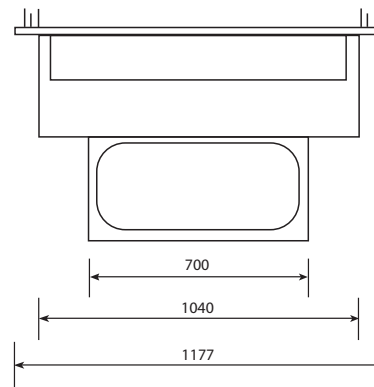

G/N CAPACITY 4
CUT-OUT SIZE 1370 x 646/796

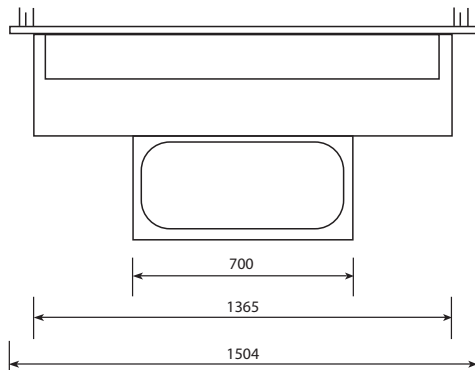

G/N CAPACITY 5 (NOT DRDD)
CUT-OUT SIZE 1700 x 646

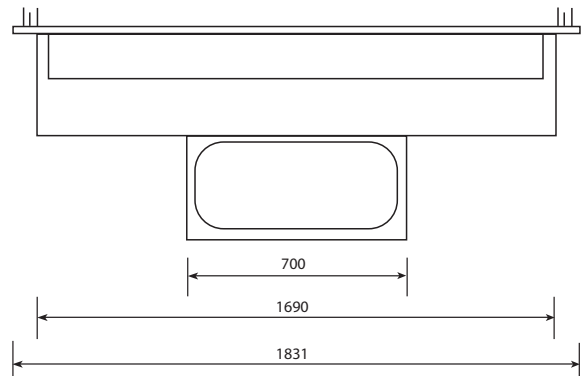

AutoCAD blocks can be downloaded from www.victoronline.co.uk

DIMENSIONS - DRMT, SSRMT

Multi tier 2 shelf / Multi tier 3 shelf (Measurements in mm)

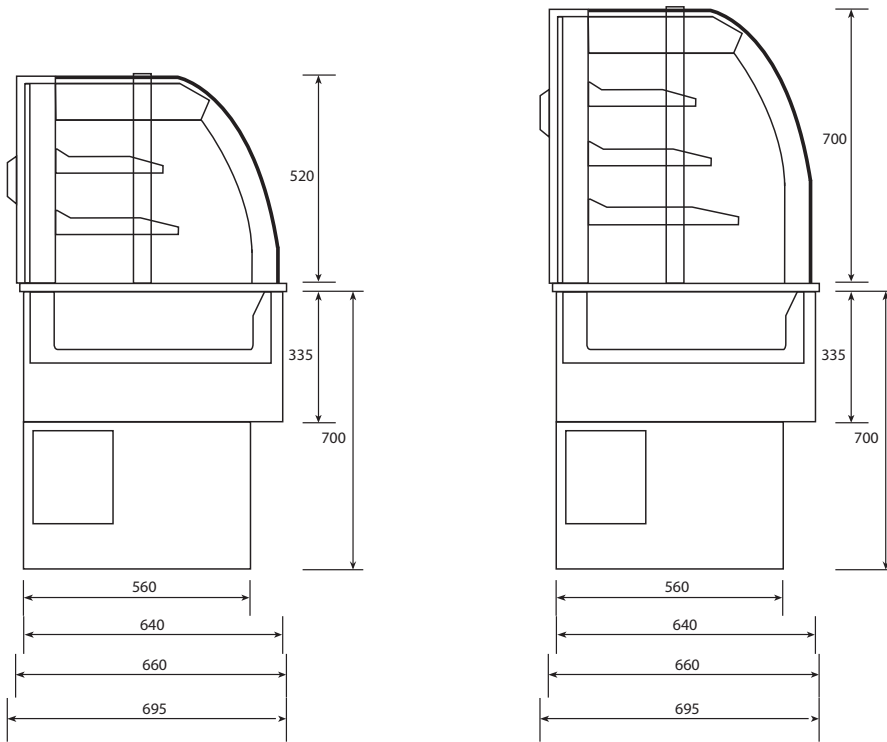

G/N CAPACITY 2
CUT-OUT SIZE 725 x 646

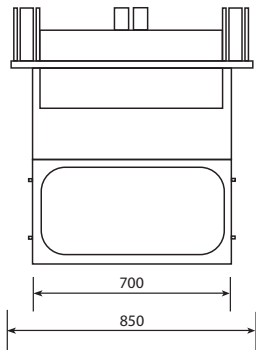

G/N CAPACITY 3
CUT-OUT SIZE 1045 x 646

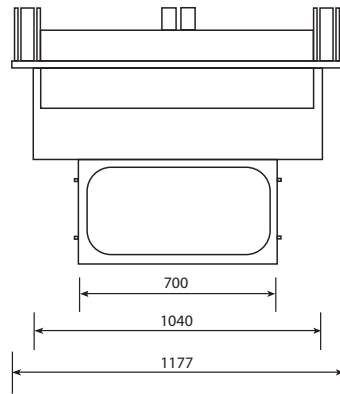

G/N CAPACITY 4
CUT-OUT SIZE 1370 x 646

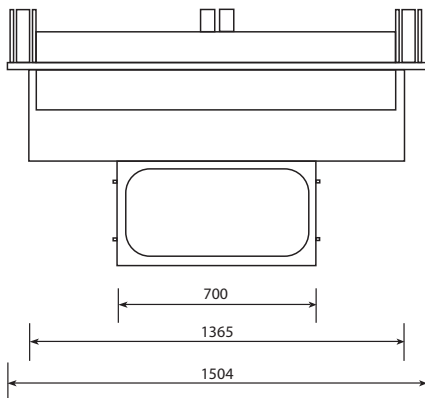

G/N CAPACITY 5
CUT-OUT SIZE 1700 x 646

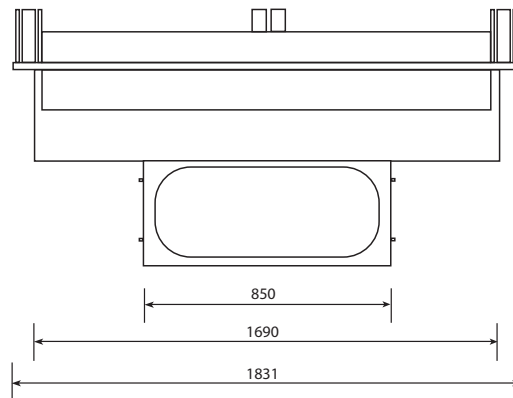

AutoCAD blocks can be downloaded from www.victoronline.co.uk

NOTES

Empty rectangular box for notes.

Victor Manufacturing Limited
Back Prospect Works
Off South Street
Keighley BD21 5AA
01274 722125
sales@victormfg.co.uk

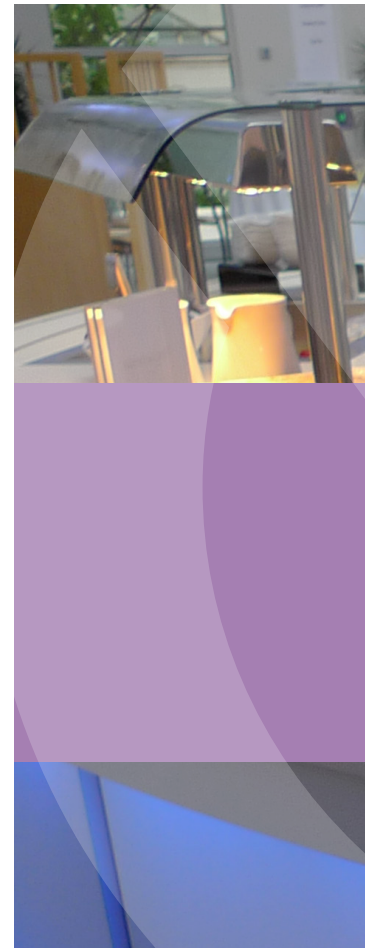

*All Victor products are
manufactured in the UK and
carry a two years warranty*