



# VICTOR

# QHS BEVERAGE TROLLEY

## New Product July Launch

Created to meet the demanding needs of the NHS, our lightweight, ergonomically designed trollies enable fast and efficient service of hot beverages and cold snacks.

Ideal for use in care homes, call centres, meeting and waiting rooms. The addition of the optional beverage dispensers allows for the service of coffee, cocoa powder, sugar, sweetener, powdered creamer etc.



TELEPHONE  
01274 722125

EMAIL  
sales@victormfg.co.uk

WEBSITE  
www.victoronline.co.uk

SPECIAL PRODUCTS

**QHS BEVERAGE TROLLEY**

**MODEL NO: QHSBT / QHSBT2 / QHSBT4**

Created to meet the demanding needs of the NHS, our lightweight, ergonomically designed trollies enable fast and efficient service of hot beverages and cold snacks. Ideal for use in care homes, call centres, meeting rooms and waiting rooms.

The addition of the optional beverage dispensers allows for the service of coffee (ground or instant), sugar, powdered creamer, sweetener & cocoa powder etc.



**MODEL VARIATIONS**

- QHSBT** - Boiler only
- QHSBT2** - Boiler plus 2 dispensers
- QHSBT4** - Boiler plus 4 dispensers

**ELECTRICAL CONNECTIONS**

220V/240V; 1 phase 50Hz, 1.5kW loading, 6.25Amps approx  
Cable: 2.5 metres with 13 amp plug fitted

**PRODUCT FEATURES**

- ❑ Wipe clean surfaces
- ❑ Removable trays allowing for varied sized product storage
- ❑ Break plug for safety with plug storage point built into handle for transportation purposes
- ❑ Front bumper to protect trollies and doorways when being manoeuvred
- ❑ Boiler contained within own housing to prevent the possibility of burns and create a secondary insulation area
- ❑ Fitted with shrouded grey thermoelastic rubber tyred castors for adherence to infection control criteria.

**PRICING**

Model No.	List Price	Delivery
<b>QHSBT</b>	£4,480	£80
<b>QHSBT2</b>	£5,175	£80
<b>QHSBT4</b>	£5,790	£80

To April 2025

**DISPENSER FEATURES**

- ❑ Black ABS lid and funnel
- ❑ 1 x tsp per serving
- ❑ 1.5 litre capacity per cylinder
- ❑ Pull "Click Trigger" & Serv mechanism
- ❑ BPA Free and complies with FDA and EU food contact material regulations

**BOILER FEATURES**

- ❑ Water level indicator
- ❑ Anti-drip dispenser tap
- ❑ Automatic re-boil temperature control
- ❑ Lockable lid
- ❑ Concealed element
- ❑ 10 litre capacity
- ❑ 1500w power
- ❑ 220 - 240v AC operation

**BESPOKE OPTIONS**

- ❑ Bespoke, changeable printed panels to front and end. Perfect for displaying company details, offers or logo.

**DIMENSIONS**

External: 1230mm x 600mm x 1426mm

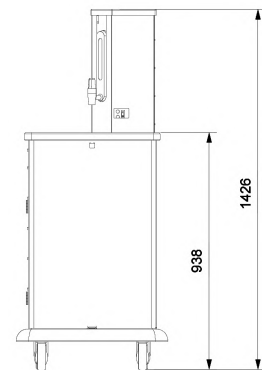
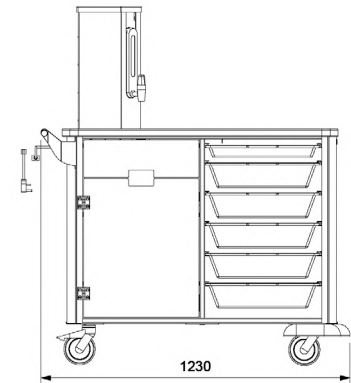
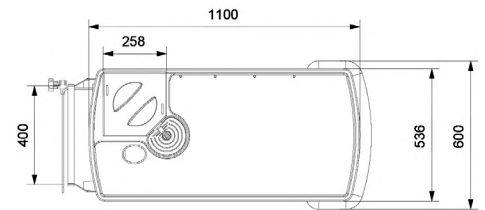

**TELEPHONE**  
01274 722125

**EMAIL**  
sales@victormfg.co.uk

**WEBSITE**  
www.victoronline.co.uk